

**STATE OF HAWAII  
DEPARTMENT OF TRANSPORTATION  
AIRPORTS**

**SPECIFICATIONS AND PROPOSAL  
FOR  
AIRFIELD SIGN PANELS, LIGHTING, & RETROFIT  
STATEWIDE  
PROJECT NO. BS1521-53R**

**NOTICE TO BIDDERS**  
Hawaii Revised Statutes (HRS),  
Chapter 103D

The receiving of bids for **AIRFIELD SIGN PANELS, LIGHTING, & RETROFIT, STATEWIDE, PROJECT NO. BS1521-53R**, will begin as of the HiePRO Release Date.

Bidders shall register and submit complete bids through HiePRO only. Refer to the following HiePRO link for important information on Vendor Registration:

<https://hiepro.ehawaii.gov/welcome.html>.

The solicitation, specifications, proposal, and additional documents designated or incorporated by reference shall be available in HiePRO.

HiePRO OFFER DUE DATE AND TIME is August 3, 2026, at 2:00 p.m., Hawaii Standard Time (HST). **Bidders shall submit and upload the complete proposal to HiePRO prior to the offer due date and time. Proposals received after said due date and time shall not be considered. Any additional support documents explicitly designated as confidential and/or proprietary shall be uploaded as a separate file to HiePRO. Bidders shall not include confidential and/or proprietary documents as part of their proposal. The record of each bidder and their respective proposal shall be open to public inspection. FAILURE TO UPLOAD THE PROPOSAL TO HiePRO SHALL BE GROUNDS FOR REJECTION.**

The scope of work consists of furnishing replacement airfield signs, airfield sign panels, LED sign retrofit kits, airfield lights and/or reflectors on an open end, “as-needed” basis for maintenance of airfield signs and lighting, at Statewide Airports.

All Request for Information (RFI) questions and Substitution Requests shall be submitted in HiePRO **no later than July 17, 2026, at 2:00 p.m., HST.** RFI questions received after the stated deadline shall not be addressed. Substitution Requests received after the stated deadline

shall not be considered. Verbal RFI(s) shall not receive a response. All responses to RFI questions shall be provided for clarification and information only and issued by formal addendum. Any amendments to the solicitation shall be made by formal addendum and posted in HiePRO.

If there is a conflict between the solicitation and information stated in the responses to RFI questions, the solicitation shall govern and control, unless as amended by formal addendum.

Campaign contributions by State and County Contractors. Contractors are hereby notified of the applicability of HRS § 11-355 which states that campaign contributions are prohibited from specified State or County government contractors during the term of the contract if the contractors are paid with funds appropriated by a legislative body. For more information, contact the Campaign Spending Commission at (808) 586-0285.

Protests. Any protest of this solicitation shall be submitted in writing to the Director of Transportation, in accordance with HRS § 103D-701 and Hawaii Administrative Rules § 3-126.

The Equal Employment Opportunity Regulations of the Secretary of Labor implementing Executive Order 11246, as amended, shall be complied with on this project.

The U.S. Department of Transportation Regulation entitled “Nondiscrimination in Federally Assisted Programs of the U.S. Department of Transportation,” Title 49, Code of Federal Regulations (CFR), Part 21, is applicable to this project. Bidders are hereby notified that the Department of Transportation shall affirmatively ensure that the contract entered into pursuant to this advertisement shall be awarded to the lowest responsible bidder without discrimination on the grounds of race, color, national origin, or sex (as directed by 23 CFR Part 200).

For additional information, contact Maybelle Lee, State Project Manager, by phone at (808) 838-8890, or by email at maybelle.p.lee@hawaii.gov.

The State reserves the right to reject any or all proposals and to waive any defects in said proposals in the best interest of the public.



---

CURT T. OTAGURO  
Deputy Director of Transportation for Airports

HIePRO RELEASE DATE: June 24, 2026

TABLE OF CONTENTS

PAGE

Special Provisions.....SP-1 - SP-2

Specifications

|            |   |             |
|------------|---|-------------|
| Section 1  | Definition of Terms.....                            | 1-1 - 1-4   |
| Section 2  | Proposal Requirements<br>and Conditions.....        | 2-1 - 2-3   |
| Section 3  | Award and Execution<br>of Contract.....             | 3-1 - 3-4   |
| Section 4  | Scope of Work.....                                  | 4-1 - 4-3   |
| Section 5  | Control of Work .....                               | 5-1 - 5-2   |
| Section 6  | Control of the Material<br>and Equipment.....       | 6-1 - 6-3   |
| Section 7  | Legal Relations<br>and Responsibility.....          | 7-1 - 7-4   |
| Section 8  | Prosecution and Progress.....                       | 8-1 - 8-7   |
| Section 9  | Payment.....  | 9-1 - 9-2   |
| Section 10 | Airfield Signage, Lighting,<br>and Visual Aids..... | 10-1 - 10-8 |

Proposal.....PF-1 - PF-5

    Proposal Schedule..... PF-6 - PF-12

Exhibits

    Exhibit - Sample Sign Inventory(s).....1 - 42

Forms

    Sample Contract

STATE OF HAWAII  
DEPARTMENT OF TRANSPORTATION  
HONOLULU, HAWAII

SPECIAL PROVISIONS

## SPECIAL PROVISIONS

The Specifications contained herein are amended as follows:

### A. SECTION 1 - DEFINITION AND TERMS

1. 1.33 SUBCONTRACTOR is amended by deleting it and replacing it with the following:

"1.33 SUBCONTRACTOR - An individual, partnership, firm, corporation, or joint venture, or other legal entity, as licensed or required to be licensed under Chapter 444, Hawaii Revised Statutes, as amended, which enters into an agreement with the Contractor to perform a portion of the work."

2. Add the following new definition:

"1.39 HAWAII ePROCUREMENT SYSTEM (HIePRO) - The State of Hawaii eProcurement System for issuing solicitations, receiving proposals and responses, and issuing notices of award."

### B. SECTION 2 - PROPOSAL REQUIREMENTS AND CONDITIONS

1. 2.3 DELIVERY OF PROPOSALS is amended by replacing the entire subsection with:

"2.3 DELIVERY OF PROPOSALS - **Bidders shall submit and upload the complete proposal to HIePRO prior to the bid opening date and time. Proposals received after said due date and time shall not be considered.** Original (wet ink, hard copy) proposal documents are not required to be submitted. **Contract award shall be based on evaluation of proposals submitted and uploaded to HIePRO. Any additional support documents explicitly designated as confidential and/or proprietary shall be uploaded as a separate file to HIePRO. Bidders shall not include confidential and/or proprietary documents with the proposal.** The record of each bidder and respective bid shall be open to public inspection.

**FAILURE TO UPLOAD THE COMPLETE PROPOSAL TO HIePRO SHALL BE GROUNDS FOR REJECTION OF THE BID.**

If there is a conflict between the specification document and the HIePRO solicitation, the specifications shall govern and control, unless otherwise specified."

2. 2.4 WITHDRAWAL OF PROPOSALS is amended by replacing the entire subsection with:

"2.4 WITHDRAWAL OF PROPOSALS - Bids may be modified or withdrawn prior to the bid opening date and time. Withdrawal or revision of proposal shall be completed, and submitted and uploaded to HIEPRO prior to the bid opening date and time."

3. 2.5 PUBLIC OPENING OF PROPOSALS is not applicable.

- C. SECTION 6 - CONTROL OF MATERIAL AND EQUIPMENT - is amended as follows:

6.2 TRADE NAMES AND ALTERNATES is amended as follows:

1. The first paragraph of A. QUALIFICATION BEFORE BID OPENING shall be replaced with the following:

"A. QUALIFICATION BEFORE BID OPENING - When the specifications and/or plans specify one or more manufacturer's brand names of materials or equipment to indicate a quality, style, appearance, or performance, the bidder will be assumed to have based its bid on one of the specified named products, except where such proprietary product are specified, alternate brands may be qualified if found equal or better by the Department. The bidder shall submit a request to the Department for review and approval at the earliest date possible. As specified in the Notice to Bidders, all requests shall be posted as a question in HIEPRO under the "Question and Answer" tab. Supporting documents for specific request shall be emailed to the Project Manager specified in the Notice to Bidders. Request must be posted in HIEPRO and supporting documents received by the Project Manager no later than fourteen (14) calendar days before the bid opening date.

2. The first sentence of the second paragraph of A. QUALIFICATION BEFORE BID OPENING shall be replaced with the following:

"It shall be the responsibility of the bidder to submit sufficient evidence based upon which a determination can be made by the Department that the alternate brand is a qualified equivalent."

STATE OF HAWAII  
DEPARTMENT OF TRANSPORTATION  
HONOLULU, HAWAII

SPECIFICATION

## SECTION 1 - DEFINITION AND TERMS

Whenever the following pronouns are used in these specifications, or in any documents or instruments where these specifications govern, the intent and meaning shall be interpreted as follows:

1.1 ADDENDA - A written document which may be issued by the Director during the bidding period involving changes to the specifications and plans, if any, which shall be considered and made a part of the contract.

1.2 AIRPORTS DIVISION - Airports Division, Department of Transportation, State of Hawaii.

1.3 AWARD - The written acceptance of a proposal by the State.

1.4 BIDDER - Any individual, partnership, corporation or other legal entity, or combination thereof, submitting a proposal for the work contemplated, acting either directly or through a duly authorized representative.

1.5 CALENDAR DAY - Every day shown on the calendar. If no designation of calendar or working day is made, "day" shall mean calendar day.

1.6 CHANGE ORDER - A written order issued by the Director to the Contractor requiring the contract work to be performed in accordance with a change or changes that may involve an adjustment in contract time and price or requiring performance of any unforeseen work essential to complete the contract.

1.7 CONTRACT - The written agreement between the State and the Contractor setting forth the obligations of the parties thereunder, including, but not limited to, the performance of the work, the furnishing of labor and materials, and the basis of payment.

The contract includes the (1) notice to bidders, (2) proposal, (3) contract form and contract bond, (4) specifications, (5) special provisions and plans, if any, (6) addenda, (7) notice to proceed, and (8) change orders and agreements that are required to complete the work, all of which constitute one instrument.

1.8 CONTRACT BOND - The approved form of security, executed by the Contractor and its Surety or Sureties, guaranteeing the completion of the work in accordance with the terms of the contract, and guaranteeing full payment of all claims for labor, materials, and supplies used or incorporated in the work.

1.9 CONTRACT TIME - The number of working days or calendar days allowed for completion of the contract, including authorized time extensions.

If a calendar date is specified as the date of completion in lieu of the number of working days or calendar days, the contract shall be completed by that date.

In case the contract is for a specified period of time, the contract time shall be for said specified period of time.

1.10 CONTRACTOR - The individual, partnership, corporation or other legal entity, or combination thereof, contracting with the State for performance of the prescribed work.

1.11 DEPARTMENT - The State Department of Transportation.

1.12 DIRECTOR - The Director of Transportation, acting either directly or through the Director's duly authorized representative.

1.13 EQUAL OR APPROVED EQUAL - Whenever this term is used in the specifications and plans, if any, it means a brand or article pre-qualified in accordance with Section 6.2 Trade Names and Alternates and which may be used in place of the one specified.

1.14 H.A.R. or HAR - Hawaii Administrative Rules.

1.15 H.R.S. or HRS - Hawaii Revised Statutes.

1.16 HARBORS DIVISION - Harbors Division, Department of Transportation, State of Hawaii.

1.17 HIGHWAYS DIVISION - Highways Division, Department of Transportation, State of Hawaii.

1.18 HOLIDAYS - The days which are set apart and established as State holidays pursuant to Section 8-1, H.R.S.

1.19 INSPECTOR - The Director's authorized representative assigned to make detailed inspections of contract performance and materials supplied.

1.20 NOTICE TO BIDDERS - The public announcement, as required by law, inviting proposals for the work to be performed or materials to be furnished.

1.21 NOTICE OF FINAL ACCEPTANCE - Written notice from the Director to the Contractor that the entire contract has been completed in all respects in accordance with the specifications and plans, if any, and any changes thereof previously approved by the Director.

1.22 NOTICE TO PROCEED - Written notice from the Director to the Contractor advising the Contractor of the date on which he is to begin the prosecution of the work.

1.23 PLANS - The contract drawings approved by the Director which show the location, character, dimensions and details of the work to be done and shall be a part of the contract.

1.24 PROCUREMENT OFFICER - The Director's duly authorized representative including project managers, project engineers and contract administrators assigned to prepare, evaluate and administer contracts for the purchasing of goods and services.

1.25 PROPOSAL (OR BID) - The offer of a bidder, on the prescribed form, to perform the work and to furnish the labor and materials at the prices quoted.

1.26 PROPOSAL FORM - The approved format prepared by the Department or a facsimile thereof on which bids for the work must be prepared and submitted. (Reasonable facsimile acceptable for bidding.)

1.27 PROPOSAL GUARANTY - The security furnished with a proposal to guarantee that the bidder will enter into the contract and furnish all other requirements if the bidder's proposal is accepted.

1.28 QUALIFICATION QUESTIONNAIRE - The specified forms on which the bidder shall furnish required information as to the bidder's ability to perform and finance the work.

1.29 S.L.H. or SLH - Session Laws of Hawaii.

1.30 SPECIAL PROVISIONS - Revisions to the specifications. The specific clauses setting forth conditions or requirements peculiar to the project under consideration which are not thoroughly or satisfactorily stipulated in these specifications.

1.31 SPECIFICATIONS - The directions, provisions, and requirements pertaining to the method and manner of performing the work and to the quantities and qualities of materials to be furnished under the contract.

1.32 STATE - The State of Hawaii.

1.33 SUBCONTRACTOR - An individual, partnership, corporation, other legal entity, or any combination thereof, that enters into an agreement with the Contractor to perform a portion of the work for the Contractor.

1.34 SUPERINTENDENT - The Contractor's representative who is responsible for and in charge of the work.

1.35 SURETY - The corporation, partnership or individual, other than the Contractor, executing a bond furnished by the Contractor and guaranteeing performance by the Contractor.

1.36 TITLES (OR HEADINGS) - The titles or headings of the Sections herein are intended for convenience of reference and shall not be considered as having any bearing on their interpretation. Unless otherwise indicated, whenever the word "Section" is used, reference is being made to a Section in these specifications.

1.37 WORK - The furnishing of all labor, materials, equipment, and other incidentals necessary or convenient for the successful completion of the project and the execution of all the duties and obligations imposed by the contract.

1.38 WORKING DAY - Any day, except Saturdays, Sundays and State holidays.

## SECTION 2 - PROPOSAL REQUIREMENTS AND CONDITIONS

2.1 PROPOSAL FORMS - All proposals shall be made on forms furnished by the Department. All proposals shall give the prices proposed in the spaces provided and shall be signed by the bidder, who shall fill out all blanks in the proposal form as therein required.

2.2 REJECTION OF PROPOSALS CONTAINING ALTERATIONS, ERASURES, OR IRREGULARITIES - Proposals may be rejected if they show any alterations of form, additions not called for, conditional bids, incomplete bids, erasures, or irregularities of any kind.

When proposals are signed by any agent, other than the officer or officers of a corporation authorized to sign contract on its behalf or a member of copartnership, a Power of Attorney must be on file with the Department prior to opening bids or shall be submitted with the proposal; otherwise, the proposal may be rejected as irregular and unauthorized.

Members of a joint venture may be requested to supply the Department with a copy of their joint venture agreement or each member of the joint venture may be required to sign the proposal.

2.3 DELIVERY OF PROPOSALS - Each proposal shall be placed, together with the proposal guaranty, when required, in an envelope and sealed and so marked as to indicate the identity of the project, the name and address of the bidder, and other required information and then delivered as indicated in the Notice to Bidders. Proposals will be received up to the time fixed in the Notice to Bidders for the opening of bids.

2.4 WITHDRAWAL OF PROPOSALS - Any proposal may be withdrawn at any time prior to the time fixed in the Notice to Bidders for the opening of proposals upon the filing of a written request therefor with the Department, executed by the bidder or his duly authorized representative. The withdrawal of a proposal shall not preclude a bidder from submitting a new proposal.

2.5 PUBLIC OPENING OF PROPOSALS - Proposals will be opened and read publicly at the time and place indicated in the Notice to Bidders. Bidders or their authorized agents are invited to be present.

2.6 DISQUALIFICATION OF BIDDERS - Any of the following reasons may be considered as being sufficient grounds for the disqualification of a bidder and the rejection of his proposal or proposals.

A. More than one proposal for the same work from an individual, firm, or corporation under the same or different name.

B. Evidence of collusion among bidders. Participants in such collusion will receive no recognition as bidders for any future work of the Department until such participant shall have been reinstated as a qualified bidder.

C. Evidence of assistance from a person who has been an employee of the agency within the preceding two years and who participated while in State office or employment in the matter with which the contract is directly concerned, pursuant to Section 84-15, HRS.

D. Lack of proposal guaranty.

E. Unsigned proposal or proposal not signed in ink by person or persons legally authorized to submit a proposal on behalf of the bidder.

2.7 MATERIAL GUARANTY - The bidder may be required to furnish a complete statement of the origin, composition and manufacture of any or all materials to be used in the prosecution of the work, together with samples. Such samples may be subjected to tests to determine their quality and fitness for the work.

2.8 OUT-OF-STATE BIDDERS - Pursuant to Section 103D-1008, Hawaii Revised Statutes, on out-of-state purchases where the bidder or vendor is an out-of-state vendor, not doing business in the State, the bid price of such out-of-state vendor, for the purpose of determining the lowest price bid, shall be increased by the applicable retail rate of general excise tax and the applicable use tax. The lowest responsible bidder, taking into consideration the above increases, shall be awarded the contract, but the contract amount of any contract awarded shall be the amount of the bid offered and shall not include the amount of said increases.

Such increases will not be applied in case an out-of-state vendor specifies in its bid that its bid price includes said general excise tax; the bidder will be required to pay said general excise tax and use tax in case the bidder is awarded the contract.

2.9 TAX REQUIREMENTS - Work to be done under this contract is a taxable transaction and the bidder receiving the award for this work will be required to pay the State of Hawaii General Excise Tax (GET) and the State of Hawaii use Tax.

Additional information regarding the tax rates may be obtained from the Department of Taxation (DOTAX) website at <http://tax.hawaii.gov/geninfo/countysurcharge/>

If awardee is an out-of-state bidder not holding a Hawaii GET License, the awardee will have to obtain a Hawaii GET License and pay all taxes due to obtain a tax clearance required before final contract payment is made by the State.

To obtain the tax clearance applications, see subsection 3.1.A. Tax Clearance of these Specifications.

Vendors may apply for either a regular or a one-time GET License. Information on applying for a GET License may be found at <http://tax.hawaii.gov/geninfo/get/>

SECTION 3 - AWARD AND EXECUTION OF CONTRACT

3.1 AWARD OF CONTRACT - The State reserves the right to reject any and all proposals and to waive any defects as may be deemed to be in the best interest of the public.

The award of contract, if it be awarded, shall be made within sixty (60) calendar days after the opening of bids to the lowest responsive and responsible bidder whose proposal complies with all the prescribed requirements. The Department may request the bidders to allow the Department to consider the bids for the issuance of an award beyond the sixty (60) calendar day period. Agreement to such an extension shall be made by a bidder in writing. Only bidders who have agreed to such an extension shall be eligible for the award. No response to request shall mean bidder shall no longer be eligible for award.

**Requirement for award.** The Bidder, as proof of compliance with the requirements of section 103D-310(c), HRS, upon award of a contract made pursuant to section 103D-302, HRS, shall provide the documents listed below. The documents shall be submitted promptly to the Department. If a valid certificate/clearance is not submitted on a timely basis upon award, the Bidder may be deemed non-responsible.

**A. Tax Clearance.**

Pursuant to section 103D-310(c), 103-53 and 103D-328, HRS, the bidder shall submit a tax clearance certificate from the State of Hawaii Department of Taxation (DOTAX) and the Internal Revenue Service (IRS), subject to section 103D-328, HRS, current within six months of issuance date.

FORM A6, TAX CLEARANCE CERTIFICATE, is available at the following website:

<https://tax.hawaii.gov/>

To receive DOTAX Forms by fax or mail, phone (808)587-4242 or 1-800-222-3229.

The application for the Tax Clearance Certificate is the responsibility of the bidder. Bidder shall submit directly to the DOTAX or IRS. The approved certificate may then be submitted to the Department.

**B. Certificate of Compliance.**

Pursuant to section 103D-310(c), HRS, the bidder shall submit a certificate of compliance for Hawaii Employment Security Law (Chapter 383, HRS), Workers' Compensation Law (Chapter 386, HRS), Temporary Disability Insurance (Chapter 392, HRS), and Prepaid Health Care Act (Chapter 393, HRS), from the State of Hawaii Department of Labor and Industrial Relations (DLIR), current within six months of issuance date.

Form LIR#27, Application for Certificate of Compliance with section 3-122-112, HAR, is available at the following website:

<https://labor.hawaii.gov/>

Contact the DLIR Unemployment Insurance Division at (808) 586-8926 for additional information.

Inquiries regarding the status of a LIR#27 Form are available from the DLIR Disability Compensation Division at (808)586-9200.

The application for the Certificate of Compliance is the responsibility of the bidder. Bidder shall submit directly to the DLIR. The approved certificate may then be submitted to the Department.

**C. Certificate of Good Standing.**

Pursuant to section 103D-310(c), HRS, the bidder shall submit a certificate of good standing from the business registration division (BREG) of the State of Hawaii Department of Commerce and Consumer Affairs (DCCA), current within six months of issuance date, to demonstrate it is either:

- (1) incorporated or organized under the laws of the State; or
- (2) registered to do business in the State as a separate branch or

division that is capable of fully performing under the contract.

A Hawaii business that is a sole proprietorship, is not required to register with the BREG, and therefore not required to submit a certificate of good standing. Bidders are advised of costs associated with registering and obtaining a Certificate of Good Standing from the DCCA.

To purchase a Certificate of Good Standing, go to On-Line Services at the following website:

<https://cca.hawaii.gov/>

The application for the Certificate of Good Standing is the responsibility of the bidder. Bidder shall submit directly to the DCCA. The approved certificate may then be submitted to the Department.

**D.** IN LIEU OF the certificates referenced in subsection A, B, and C, bidder may make available proof of compliance through a state procurement office designated certification process.

3.2 CANCELLATION OF AWARD - The State reserves the right to cancel the award of any contract any time before the execution of said contract by all parties without any liability to the successful bidder or any other bidder.

3.3 EXECUTION OF CONTRACT - The contract shall be executed by the successful bidder and returned, together with the contract bonds, when required, within ten (10) days after the award of the contract or within such further time as the Director may allow after the bidder has received the contract for execution.

Pursuant to Section 103D-309, H.R.S., the contract shall not bind the State in any way unless said contract has been fully and properly executed by all the parties thereto and the Comptroller has endorsed thereon a certificate that there is available an unexpended appropriation over and above all outstanding contracts, sufficient to cover the amount required by the contract.

3.4 FAILURE TO EXECUTE CONTRACT - Failure to execute the contract and file acceptable bonds, when required, within

ten (10) days after the award of the contract, or within such further time as the Director may allow, shall be cause for the cancellation of the award and the forfeiture of the proposal guaranty. Award of the contract may then be made to the next lowest responsible bidder.

## SECTION 4 - SCOPE OF WORK

4.1 WORK TO BE DONE - The work to be done is described in the Section(s) following Section 9 of these specifications.

4.2 PERFORMANCE OF WORK - The Contractor shall employ, so far as possible, such methods and means in carrying out his work so as not to cause any interruption, disturbance, or interference with the public.

In case the Contractor is performing work in a building, the Contractor shall conduct the work in such a manner so as not to cause any interruption, disturbance, or interference with the business activities of the tenants in the building.

4.3 EXTRA WORK - New and unforeseen items of work will be classed as extra work when they cannot be covered by any of the various items for which there is a bid price.

### 4.4 CHANGES AND CLAIMS FOR ADJUSTMENT

A. Change order. By a written order, at any time, and without notice to any surety, the procurement officer may, subject to all appropriate adjustments, make changes within the general scope of this contract in any one or more of the following:

1. Drawings, designs, or specifications, if the goods to be furnished are to be specially manufactured for the State in accordance therewith;
2. Method of shipment or packing;
3. Place of delivery;
4. Changes in the work within the scope of the contract; or
5. Changes in the time of performance of the contract that do not alter the scope of work.

B. Adjustments of price or time for performance. If any change order increases or decreases the contractor's cost of, or the time required for, performance of any part of the work under this contract, whether or not changed by the order, an adjustment shall be made and the contract modified in writing accordingly. Any adjustment in contract price made pursuant to this clause shall be determined in accordance with the price adjustment clause of this contract. Failure of the parties to agree to an adjustment shall not excuse the contractor from proceeding with the contract as changed, provided that the procurement officer promptly and duly make the provisional adjustments in payment or time for performance as may be reasonable. By proceeding with the work, the contractor shall not be deemed to have

prejudiced any claim for additional compensation, or an extension of time for completion.

C. Time period for claim. Within thirty (30) days after receipt of a written change order under subsection (a) unless the period is extended by the procurement officer in writing, the contractor shall file notice of intent to assert a claim for an adjustment. Later notification shall not bar the contractor's claim unless the State or county is prejudiced by the delay in notification.

D. Claim barred after final payment. No claim by the contractor for an adjustment hereunder shall be allowed if notice is not given prior to final payment under this contract.

E. Other claims not barred. In the absence of a change order, nothing in this clause shall be deemed to restrict the contractor's right to pursue a claim as under the contract or for breach of contract.

#### 4.5 PRICE ADJUSTMENT

Any adjustment in contract price pursuant to a clause in this contract shall be made in one or more of the following ways:

A. By agreement on a fixed price adjustment before commencement of the pertinent performance or as soon thereafter as practicable;

B. By unit prices specified in the contract or subsequently agreed upon;

C. By the costs attributable to the event or situation covered by the clause, plus appropriate profit or fee, all as specified in the contract or subsequently agreed upon;

D. In such other manner as the parties may mutually agree; or

E. In the absence of agreement between the parties, by a unilateral determination by the procurement officer of the costs attributable to the event or situation covered by the clause, plus appropriate profit or fee, all as computed by the procurement officer in accordance with generally accepted accounting principles and applicable sections of chapters 3-123 and 3-126 of the Hawaii Administrative Rules.

#### 4.6 VARIATION IN QUANTITY

Upon agreement of the parties, the quantity of goods or services or both specified in this contract may be increased by a maximum of ten (10) percent provided (1) the unit prices will remain the same except for any price adjustments otherwise applicable and (2) the procurement officer makes a written determination that such an increase will either be more economical than awarding another contract or that it would not be practical to award another contract.

SECTION 5 - CONTROL OF WORK

5.1 AUTHORITY OF DIRECTOR - The Director shall decide all questions which may arise as to the quality or acceptability of materials furnished and work performed, the manner of performance and rate of progress of the work, and compensation for work performed, interpretation of the contract and fulfillment of the contract on the part of the Contractor. The Director shall have authority to enforce and make effective such decisions and orders which the Contractor fails to carry out properly and diligently. The decision of the Director shall be final.

5.2 COORDINATION OF PLANS, SPECIFICATIONS AND SPECIAL PROVISIONS - These specifications, plans, special provisions, and all supplementary documents are essential parts of the contract, and a requirement occurring in one is as binding as though occurring in all. They are intended to be complementary and to describe and provide for a complete work.

5.3 CLAIMS AND DISPUTES - The Contractor may give notice in writing to the procurement officer for claims that extra compensation, damages, or an extension of time for completion is due the Contractor for one or more of the following reasons:

- A. Requirements not clearly covered in the contract, or not ordered by the procurement officer as an extra work;
- B. Failure between the State and the Contractor to agree to an adjustment in price for a contract change order issued by the State; or
- C. An action or omission on the part of the procurement officer requiring performance changes within the scope of the contract.

The Contractor shall continue with performance of the contract in compliance with the directions or orders of the procurement officer, but by so doing, the Contractor shall not be deemed to have prejudiced any claim for additional compensation, damages, or an extension of time for completion; provided:

- A. The notice in writing be given:
  - 1. Before the commencement of the work involved, if at that time the Contractor knows of such requirements or the occurrence of such actions or omissions; or
  - 2. Within thirty (30) calendar days after the

Contractor knows of such requirements or the occurrence of such action or omission if the Contractor did not have such knowledge before the commencement of the work; or

3. Within thirty (30) calendar days after receipt of the written contract change order that was not agreed upon by both parties; or

4. Within such further time as may be allowed by the procurement officer in writing.

B. The notice shall clearly state the Contractor's intention to make claim and the reasons why the Contractor believes that additional compensation, changes or an extension of time may be remedies to which the Contractor is entitled; and afford the procurement officer every facility for keeping records of the actual cost of work. Failure on the part of the Contractor to give such notification or to afford the procurement officer proper facilities for keeping strict account of actual cost shall constitute waiver of the claim for such extra compensation. The filing of such notice by the Contractor and the keeping of costs by the procurement officer shall not in any way be construed to prove the validity of the claim.

The procurement officer will review the notice and render a decision. The procurement officer's decision shall be final and conclusive unless, within thirty (30) calendar days from the date of the decision, the Contractor mails or otherwise furnishes a written appeal to the Director. The decision of the Director shall be final. Later notification of such claims shall not bar the Contractor's claim unless the State is prejudiced by the delay in notification. No claim by the Contractor for an adjustment hereunder shall be allowed if notice is not given before final payment under this contract. Any adjustment in the contract price made pursuant to this clause shall be determined according to Section 4.5 - Price Adjustment.

The provisions of this Section shall not be construed as establishing any claims contrary to the terms of Section 4.4 - Changes and Claims for Adjustment.

Nothing herein contained, however, shall excuse the Contractor from compliance with any rules of law precluding any state officers and any Contractors from acting in collusion or bad faith in issuing or performing contract change orders which are clearly not within the scope of the contract.

SECTION 6 - CONTROL OF MATERIAL AND EQUIPMENT

6.1 DEFECTIVE MATERIALS - All materials not conforming to the requirements of these specifications or the special provisions shall be considered defective and all such materials, whether in place or not, shall be rejected. They shall be removed immediately from the site of the work, unless otherwise permitted by the Director. No rejected materials, the defects of which have been subsequently corrected, shall be used until approval in writing has been given by the Director. Upon failure on the part of the Contractor to comply promptly with any order to remove and replace defective materials, the Director may remove and replace defective material and to deduct the cost of removal and replacement from any monies due or to become due the Contractor.

6.2 TRADE NAMES AND ALTERNATES - For convenience in designation on the plans or in the specifications, certain equipment or articles or materials may be designated under a trade name or the name of a manufacturer and its information catalogue. The use of alternate equipment or an article or material which is of equal quality and of the required characteristics for the purposes intended will be permitted, subject to the written approval of the Director, in accordance with the following requirements:

A. QUALIFICATION BEFORE BID OPENING - When the specifications and/or plans specify one or more manufacturer's brand names of materials or equipment to indicate a quality, style, appearance, or performance, the bidder will be assumed to have based its bid on one of the specified named products, except where such proprietary product are specified, alternate brands may be qualified if found equal or better by the Director. Bidders requesting qualification of alternate proprietary products must submit a request to the Director for review and approval at the earliest date possible, but in any event, such request must be received at the Contracts office not later than ten (10) days before the bid opening date, not including the bid opening date.

It shall be the responsibility of the bidder to submit sufficient evidence based upon which a determination can be made by the Director that the alternate brand is qualified. The evidence shall be transmitted with a covering letter which shall list the evidence submitted and the items for which the substitution is requested.

If the evidence accompanying a request for substitution is insufficient to qualify a particular

model, the request shall be denied provided that further evidence may be submitted to qualify the item five (5) days prior to the bid opening date if the initial request was made prior to the deadline set above.

B. SUBSTITUTION AFTER BID OPENING - Substitution of material or equipment will not be allowed after the bid opening date except under the following unforeseen circumstances:

1. If a specified or pre qualified item is delayed by a lengthy strike in the factory or other unforeseeable contingency beyond the control of the Contractor which would cause an abnormal delay in the project completion.
2. If a specified or pre qualified item is found to be unusable due to change or other circumstances.
3. If the Contractor is willing to provide a more recently developed or manufactured item of material or equipment of the same manufacturer which the Director determines to be equal or better than the one specified or pre-qualified.

A substitution request, regardless of reason, shall be fully explained in writing by the Contractor and shall include its justification for said request, the quantities and unit prices involved, quotations and such other documents as are deemed necessary to support the request. Any savings in cost will accrue to the State and any additional cost for the substituted items will be paid by the Contractor.

The burden of proof as to the comparative quality and suitability of alternate equipment, articles, or materials shall be upon the bidder or Contractor and bidder or Contractor shall furnish, at its own expense, all information necessary or related thereto as required by the Director. The Director shall be the sole judge as to the comparative quality and suitability of alternate equipment, articles or materials and the Director's decisions shall be final.

The above shall not be construed to mean that substitution for brand name specified materials and equipment will be allowed; the Director reserves the right to deny any request he deems irregular or not in the best interest of the State.

6.3 ASSIGNMENT OF ANTITRUST CLAIMS FOR OVERCHARGES FOR GOODS AND MATERIALS PURCHASED

A. Vendor and purchaser recognize that in actual economic practice, overcharges resulting from antitrust violations are in fact usually borne by the purchaser. Therefore, vendor hereby assigns to purchaser any and all claims for such overcharges as to goods and materials purchased in connection with this order or contract, except as to overcharges which result from antitrust violations commencing after the price is established under this order or contract and which are not passed on to the purchaser under an escalation clause.

B. Contractor and owner recognize that in actual economic practice, overcharges resulting from antitrust violations are in fact usually borne by the owner. Therefore, contractor hereby assigns to owner any and all claims for such overcharges as to goods and materials purchased in connection with this order or contract, except as to overcharges which result from antitrust violations commencing after the price is established under this order or contract and any change order. In addition, contractor warrants and represents that each of its first tier suppliers and subcontractors shall assign any and all such claims to owner, subject to the aforementioned exception.

SECTION 7 - LEGAL RELATIONS AND RESPONSIBILITY

7.1 LAWS TO BE OBSERVED - The Contractor shall comply with all federal, state, city and county laws, ordinances, rules and regulations which in any manner affect those engaged or employed in the work, the materials used in the work, and the conduct of the work. Any reference to such laws, ordinances, rules and regulations shall include any amendments thereto effective as of the date of the call for sealed proposals.

The Contractor shall hold harmless, indemnify, defend and where appropriate, insure the State, its officers, agents and employees against any claim or liability arising from or based on the violation of any such laws, ordinances, rules or regulations. If any discrepancy or inconsistency is discovered in the contract for the work in relation to any law, ordinance, rule, regulation, order or decree, the Contractor shall forthwith report the same to the Director in writing.

7.2 PERMITS AND LICENSES - The Contractor shall procure all permits and licenses, pay all charges and fees, and give all notices necessary and incident to the due and lawful prosecution of the work.

7.3 PATENTS - The Contractor shall assume all costs arising from the use of patented materials, equipment, devices, or processes used on or incorporated in the work, and shall hold harmless, indemnify, defend and where appropriate, insure the State, its officers, agents and employees from all suits at law or actions of every nature, for or on account of the use of any patented materials, equipment, devices or processes.

7.4 RESPONSIBILITY FOR INJURY AND DAMAGE - The State, its officers, agents and employees shall not be held accountable in any manner for any loss or damage to the work or any part thereof, or for any of the materials and equipment used or employed in performing the work, or for any injury to any person or persons either workers or the public, or for any damage to property caused by the Contractor or its workers or any one employed by the Contractor. The Contractor shall be responsible for any liability imposed by law for any injury to any person or any damage to property resulting from defects or obstructions or from any cause whatsoever during the progress of the work or at any time before its completion and final acceptance. The acceptance of the completed work of the Contractor by the Director shall not relieve the Contractor from any liability which may have accrued or may accrue as a result of the performance of the work by the Contractor. The Contractor shall hold harmless, indemnify, defend and where appropriate, insure the State, its officers, agents and employees, from all suits or actions of every name, kind and description, brought for or on account of

any injuries or damages sustained by any persons or property caused by the Contractor, its servants or agents, or by or on account of any act or omission of the Contractor or its servants or agents, regardless of whether such actions or any claim is brought against them or any one of them before or after the final acceptance of the work. In addition to any remedy authorized by law, the State may withhold payment of any money due to Contractor as shall be reasonable until disposition has been made of any suits or claims for injuries or damages.

It is not the intention of the parties to this contract to make the public or any member thereof a third party beneficiary hereunder, or to authorize anyone not a party hereto to maintain a suit for personal injuries or property damage based on a contract theory of liability. In any event, the Contractor shall hold harmless, indemnify, defend and where appropriate, insure the State from suits and claims for personal injuries or property damage where such injuries or damage are caused by the negligent acts or omissions of the Contractor, its agents or employees.

7.5 COOPERATION BETWEEN CONTRACTORS - Where two or more Contractors are employed on related or adjacent work, each shall conduct its operations in such a manner as not to cause any unnecessary delay or hindrance to the other.

7.6 CONTRACTOR'S RESPONSIBILITY FOR WORK - Until the acceptance of the contract, the Contractor shall have the charge and care thereof and shall bear the risk of injury or damage to any part thereof by the action of the elements or from any other cause, whether arising from the execution or from the non-execution of the work. The Contractor shall rebuild, repair, restore, and make good all damages to any portion of the work occasioned by any of the above causes before its completion and acceptance and shall bear the expenses thereof.

7.7 NO PERSONAL LIABILITY - Neither the Director nor any other officer or authorized employee of the Department shall be personally responsible for any liability arising under the contract.

7.8 INSURANCE - Prior to commencing with the work, the Contractor shall, at its own expense, obtain and submit to the Department, Certificate of Insurance from an insurance company authorized by the laws of the State to issue such insurance in the State of Hawaii showing full policy coverage of the Contractor.

TYPES OF INSURANCE:

A. Workers' Compensation:

The Contractor shall obtain worker's compensation insurance for all persons whom they employ in carrying out the work under this contract. This insurance shall be in strict conformity with the requirements of the most current and applicable State of Hawaii Worker's Compensation Insurance laws in effect on the date of the execution of this contract and as modified during the duration of the contract. The minimum limit of liability for workers compensation is the HRS 386 statutory limit.

B. Comprehensive Automobile Liability:

The Contractor shall obtain Auto Liability Insurance covering all owned, non-owned and hired autos with a combined single Limit of not less than \$1,000,000 per accident for bodily injury and property damage with the State of Hawaii named as additional insured. The required limit of insurance may be provided by a single policy or with a combination of primary and excess policies.

C. Commercial General Liability:

The Contractor shall obtain General Liability insurance with a limit of not less than \$1,000,000 per occurrence and in the aggregates. The General liability insurance shall include the State of Hawaii as an additional insured. The required limit of insurance may be provided by a single policy or with a combination of primary and excess policies.

All policies must provide that 30 days prior written notice of cancellation or material change in coverage be given to certificate holders stated above.

Such insurance when accepted by the Director in writing shall become applicable and shall remain unmodified throughout the entire term of the contract and in no event shall be terminated or otherwise allowed to lapse prior to written certification of final acceptance of the work by the State. Such insurance aforementioned shall cover the State for all work performed under the contract, all work performed incidental thereto or directly or indirectly connected therewith, including other work performed outside of the work area, and all change orders.

Any delay in the submission and approval of insurance certificates shall not be justification of or grounds for a request by the Contractor postponing the issuance of a notice to proceed notwithstanding the fact that the Contractor shall not be allowed to proceed with the work until said certificates are submitted and approved.

Failure to obtain insurance in accordance with the Section, on the part of the Contractor, shall be considered a major breach of the contract; and should the State be forced to expend funds which would have been covered under the insurance, the Contractor agrees to assume the liability for such funds and to indemnify and hold the State harmless.

## SECTION 8 - PROSECUTION AND PROGRESS

8.1 PROGRESS OF WORK - The Contractor shall diligently prosecute the work to completion within the time limit specified in the proposal. The Contractor shall give its personal attention to the fulfillment of the contract and shall keep the work under its control. Work shall commence on the date indicated in the "Notice to Proceed" letter from the State.

8.2 LIQUIDATED DAMAGES - Time is of the essence in this contract and in case the Contractor fails to complete the work within the time specified in the proposal, damages will be sustained by the State. Since the amount of damages is difficult and not possible of definite ascertainment and proof, the amount of such damages are fixed in advance at the sum shown in the proposal for each and every calendar (or working) day which the Contractor has delayed in the completion of this contract; and the Contractor shall pay such amount as liquidated damages, and not by way of penalty, and in case the same are not paid, the State may deduct such amount thereof from any monies due or that may become due the Contractor under this contract.

If the Contractor finds it impossible for reasons beyond its control to complete the work within the contract time as specified, the Contractor shall, within 10 days from the first day of notification from the manufacturer or supplier of any delay and prior to the expiration of the contract time, make a written request to the Director for an extension of time setting forth therein the reasons which the Contractor believes will justify the granting of its request. The Contractor's plea that insufficient time was specified is not a valid reason for extension of time. If the Director finds that the work was delayed because of conditions beyond the control and without the fault of the Contractor, the Director may extend the time for completion in such extension as the conditions justify. The extended time for completion shall then be in full force and effect the same as though it were the original time for completion.

### 8.3 TEMPORARY SUSPENSION OF WORK

A. Order to stop work. The Director, may, by written order to the contractor, at any time, and without notice to any surety, require the contractor to stop all or any part of the work called for by this contract. This order shall be for a specified period not exceeding sixty (60) days after the order is delivered to the contractor, unless the parties agree to any further period. Any such order shall be identified specifically as a stop work order issued pursuant to this section. Upon receipt of such an order, the contractor shall forthwith comply with its terms and take all reasonable steps to minimize the occurrence of costs allocable to

the work covered by the order during the period of work stoppage. Before the stop work order expires, or within any further period to which the parties shall have agreed, the Director shall either:

1. Cancel the stop work order; or
2. Terminate the work covered by such order as provided in the "termination for default clause" or the "termination for convenience clause" of this contract.

B. Cancellation or expiration of the order. If a stop work order issued under this section is canceled or if the period of the order or any extension thereof expires, the contractor shall have the right to resume work. An appropriate adjustment shall be made in the delivery schedule or contract price, or both, and the contract shall be modified in writing accordingly; if:

1. The stop work order results in an increase in the time required for, or in the contractor's cost properly allocable to, the performance of any part of this contract; and
2. The contractor asserts a claim for such an adjustment within thirty (30) days after the end of the period of work stoppage; provided that, if the Director decides that the facts justify such action, any such claim asserted may be received and acted upon at any time prior to final payment under this contract.

C. Termination of stopped work. If a stop work order is not canceled and the work covered by such order is terminated for default or convenience, the reasonable costs resulting from the stop work order shall be allowable by adjustment or otherwise.

D. Adjustment of price. Any adjustment in contract price made pursuant to this clause shall be determined in accordance with the price adjustment clause of this contract.

#### 8.4 DEFAULT AND TERMINATION OF CONTRACT

A. Termination by Default. If the contractor refuses or fails to perform any of the provisions of this contract with such diligence as will ensure its completion within the time specified in this contract, or any extension thereof, otherwise fails to timely satisfy the contract provisions, or commits any other substantial breach of this contract, the Director may notify the contractor in writing of the delay or non-performance and if not cured in ten (10) days or any

longer time specified in writing by the Director, such officer may terminate the contractor's right to proceed with the contract or such part of the contract as to which there has been delay or a failure to properly perform. In the event of termination in whole or in part the Director may procure similar goods or services in the manner and upon terms deemed appropriate by the Director. The contractor shall continue performance of the contract to the extent it is not terminated and shall be liable for excess costs incurred in procuring similar goods or services.

1. Contractor's duties. Notwithstanding termination of the contract and subject to any directions from the Director, the contractor shall take timely, reasonable, and necessary action to protect and preserve property in the possession of the contractor in which the State or county has an interest.

2. Compensation. Payment for completed goods delivered and accepted by the State shall be at the contract price. Payment for the protection and preservation of property shall be in an amount agreed upon by the contractor and Director; if the parties fail to agree, the Director shall set an amount subject to the contractor's rights under chapter 3-126, HAR. The State may withhold from amounts due the contractor such sums as the Director deems to be necessary to protect the State against loss because of outstanding liens or claims of former lien holders and to reimburse the State for the excess costs incurred in procuring similar goods and services.

3. Excuse for nonperformance or delayed performance. Except with respect to defaults of subcontractors, the contractor shall not be in default by reason of any failure in performance of this contract in accordance with its terms, including any failure by the contractor to make progress in the prosecution of the work hereunder which endangers such performance, if the contractor has notified the Director within fifteen (15) days after the cause of the delay and the failure arises out of causes such as: acts of God; acts of the public enemy; acts of the State and any other governmental body in its sovereign or contractual capacity; fires; floods; epidemics; quarantine restrictions; strikes or other labor disputes; freight embargoes; or unusually severe weather. If the failure to perform is caused by the failure of a subcontractor to perform or to make progress, and if such failure arises out of causes similar to those set forth above, the contractor shall not be

deemed to be in default, unless the goods or services to be furnished by the subcontractor were unreasonably obtained from other sources in sufficient time to permit the contractor to meet the contract requirements. Upon request of the contractor, the Director shall ascertain the facts and extent of such failure, and if such officer determines that any failure to perform was occasioned by any one or more of the excusable causes, and that, but for the excusable cause, the contractor's progress and performance would have met the terms of the contract, the delivery schedule shall be revised accordingly, subject to the rights of the State under the clause entitled "Termination for Convenience". As used in this paragraph of this clause, the term "subcontractor" means subcontractor at any tier.

4. Erroneous termination for default. If, after notice of termination of the contractor's right to proceed under the provisions of this clause, it is determined for any reason that the contractor was not in default under the provisions of the clause, or that the delay was excusable under the provisions of paragraph (3), Excuse for nonperformance or delayed performance of this clause, the rights and obligations of the parties shall, if the contract contains a clause providing for termination for convenience of the State, be the same as if the notice of termination had been issued pursuant to such clause.

5. Additional rights and remedies. The rights and remedies provided in this clause are in addition to any other rights and remedies provided by law or under this contract.

B. Termination for convenience. The Director may, when the interests of the State so require, terminate this contract in whole or in part, for the convenience of the State. The Director shall give written notice of the termination to the contractor specifying the part of the contract terminated and when termination becomes effective.

1. Contractor's obligation. The contractor shall incur no further obligations in connection with the terminated work and on the dates set in the notice of termination the contractor will stop work to the extent specified. The contractor shall also terminate outstanding orders and subcontracts as they relate to the terminated work. The contractor shall settle the liabilities and claims arising out of the termination of subcontracts and orders connected with the terminated work. The Director

may direct the contractor to assign the contractor's right, title, and interest under terminated orders or subcontracts to the State. The contractor must still complete the work not terminated by the notice of termination and may incur obligations as are necessary to do so.

2. Right to goods. The Director may require the contractor to transfer title and deliver to the State in the manner and to the extent directed by the procurement officer:

- a. Any completed goods; and
- b. The partially completed goods and materials, parts, tools, dies, jigs, fixtures, plans, drawings, information, and contract rights hereinafter called "manufacturing material," as the contractor has specifically produced or specially acquired for the performance of the terminated part of this contract.

The contractor shall, upon direction of the Director, protect and preserve property in the possession of the contractor in which the State has an interest. If the Director does not exercise this right, the contractor shall use the contractor's best efforts to sell such goods and manufacturing materials. Use of this section in no way implies that the State has breached the contract by exercise of the termination for convenience clause.

3. Compensation:

a. The contractor shall submit a termination claim specifying the amounts due because of the termination for convenience together with cost or pricing data to the extent required by subchapter 15, chapter 3-122, HAR, bearing on such claim. If the contractor fails to file a termination claim within one (1) year from the effective date of termination, the Director may pay the contractor, if at all, an amount set in accordance with subparagraph c. below.

b. The Director and the contractor may agree to settlement provided the contractor has filed a termination claim supported by cost or pricing data to the extent required by subchapter 15, chapter 3-122, HAR, and that the settlement does not exceed the total contract price plus settlement costs reduced by payments previously made by the State, the

proceeds of any sales of goods and manufacturing materials under paragraph (2) of this clause, and the contract price of the work not terminated.

c. Absent complete agreement under subparagraph b above, the Director shall pay the contractor the following amounts, provided payments agreed to under subparagraph b. shall not duplicate payments under this subparagraph for the following:

(i) Contract prices for goods or services accepted under the contract;

(ii) Costs incurred in preparing to perform and performing the terminated portion of the work plus a fair and reasonable profit on such portion of the work, such profit shall not include anticipatory profit or consequential damages, less amounts paid or to be paid for accepted goods or services; provided that if it appears that the contractor would have sustained a loss if the entire contract would have been completed, no profit shall be allowed or included and the amount of compensation shall be reduced to reflect the anticipated rate of loss;

(iii) Costs of settling and paying claims arising out of the termination of subcontracts or orders pursuant to paragraph (1) of this clause. These costs must not include costs paid in accordance with subparagraph (ii) above.

(iv) The reasonable settlement costs of the contractor including accounting, legal, clerical, and other expenses reasonably necessary for the preparation of settlement claims and supporting data with respect to the terminated portion of the contract and for the termination of subcontracts thereunder, together with reasonable storage, transportation, and other costs incurred in connection with the protection or disposition of property allocable to the terminated portion of this contract. The total sum to be paid the contractor under this subparagraph shall not exceed the total contract price plus the reasonable settlement cost of the contractor reduced by the amount of

payments otherwise made, the proceeds of any sales of supplies and manufacturing materials under subparagraph b. of this paragraph, and the contract price of work not terminated.

d. Cost claimed, agreed to, or established under subparagraphs b. and c. shall be in accordance with chapter 3-123, H.A.R. bearing on such claim.

8.5 TERMINATION OF CONTRACTOR'S RESPONSIBILITY - The contract will be considered complete when all work has been completed, the work accepted by the Director, and the final estimate paid. The Contractor will then be released from further obligation except as set forth in the contract and bond, when applicable.

## SECTION 9 - PAYMENT

9.1 PAYMENT - The Contractor's bid price shall be inclusive of all costs, direct or indirect, including all taxes, required for the fulfillment of this contract.

Contract payments to the Contractor by the State shall be full payment, for furnishing all labor, and for furnishing and delivering all equipment, materials, supplies and other incidentals to the location(s) designated in these specifications.

9.2 PROGRESS PAYMENTS - If more than one shipment is required under these specifications, progress payments may be made to the Contractor after each shipment, provided the equipment materials, supplies, etc., furnished and delivered have satisfactorily met the requirements of these specifications. Five per cent (5%) of the amount of each progress payment shall be retained by the Department until the final acceptance of the work.

To expedite processing of all payments, for item(s) furnished and delivered to the Department, the Contractor shall forward an original and one copy of invoice with each shipment made to the recipient office.

Each invoice shall contain the following:

- A. Vendor's name, address and phone number.
- B. Contract or Purchase Order No.
- C. Description of item, the quantity, unit or lump sum price, sub-total and total.

9.3 FINAL ACCEPTANCE AND FINAL PAYMENT - Final acceptance means the acceptance in writing by the Director of the satisfactory completion of the work as provided under Section 8.5 followed by final payment in accordance with the Director's final estimate. The Department shall make final acceptance and payment promptly after the contract has been satisfactorily completed and final inspection made.

No payment will be made for any work which was not authorized by the Director in writing.

Final payment shall be made only after the issuance of the notice of final acceptance and after the Contractor has filed with the Director the following:

- A. Consent of the Contractor's surety, when applicable, of the final payment;

B. Satisfactory evidence by affidavit that all debts resulting from the contract have been fully paid or satisfactorily secured;

C. A current "Certificate of Vendor Compliance" issued by the Hawaii Compliance Express (HCE). The Certificate of Vendor Compliance is used to certify the Contractor's compliance with (a) Section 103D-328, HRS (for all contracts \$25,000 or more) which requires a current tax clearance certificate issued by the Hawaii State Department of Taxation and the Internal Revenue Service; (b) Chapters 383, 386, 392, and 393, HRS; and (c) Subsection 103D-310(c), HRS. The State reserves the right to verify that compliance is current prior to the issuance of final payment. Contractors are advised that non-compliance status will result in final payment being withheld until compliance is attained.

The filing of willfully false affidavits will disqualify the Contractor from bidding on future work of the Department.

SECTION 10 - AIRFIELD SIGNAGE, LIGHTING, AND VISUAL AIDS

10.1 GENERAL DESCRIPTION - The work to be performed by the Contractor under this Section, shall be furnishing and delivery to the State Department of Transportation, the following items as listed within the proposal schedule:

- A. ADB Safegate AGSF-L Airfield Guidance Sign, LED, L-858(L) signs, or approved equal
1. Size 3 L-850(L) Led airfield signs in 1 through 4 Module configurations.
    - i. Types: Y, R, L, or B.
    - ii. Style: 1, 2, 3, or 5 as required by the contract drawings and sign schedule.
  2. Size 4 L-850(L) Led airfield signs in 1 Module configuration.
    - i. Types: B or H
    - ii. Style 1, 2, 3, or 5 as required by the contract drawings and sign schedule.

Note: Sign layout to be specified upon order by State.

- B. Lumacurve replacement sign panels, or approved equal:
1. Size 3, 1 Module sign panel.
  2. Size 3, 1 Module blank sign panel.
  3. Size 4, 1 Module sign panel.

Note: Sign layout to be specified upon order by State.

- C. ADB Safegate replacement sign panels, or approved equal:
1. Size 3, 1 Module sign panel.
  2. Size 3, 2 Module sign panel.
  3. Size 3, 1 Module blank sign panel.
  4. Size 3, 2 Module blank sign panel.
  5. Size 4, 1 Module sign panel.

Note: Sign layout to be specified upon order by State.

- D. ADB Safegate LED Sign Light Engine Retrofit Kit, or approved equal for:
1. Size 3, 1 Module LED retrofit kit
  2. Size 3, 2 Module LED retrofit kit
  3. Size 3, 3 Module LED retrofit kit

4. Size 3, 4 Module LED retrofit kit
  5. Size 4, 1 Module LED retrofit kit
- E. ADB Safegate Plastic Panel Dividers, or approved equal for:
1. Size 3 Plastic Panel Divider, clear/yellow, clear/red, or black
- F. Lumacurve Plastic Panel Dividers or approved equal for:
1. Size 3 Plastic Panel Divider, clear/yellow, clear/red, or black
- G. Airfield Runway Lights
1. In-pavement Runway Edge, displaced threshold (L-850C(L)):
    - i. Bidirectional: white-white, white-yellow, white-red, yellow-red, yellow-green
  2. In-pavement Runway Threshold/end (L-850D(L))
    - i. Bidirectional: green-red, red-red
    - ii. Unidirectional: green
    - iii. Unidirectional: red
  3. In-pavement Land and Hold Short Operations (LAHSO) (L-850F)
    - i. Unidirectional: white; flashing
  4. Elevated Runway Edge, Non-precision Instrument Flight Rules (IFR) runways, displaced threshold (L-861(L))
    - i. Omnidirectional: white-yellow
    - ii. Bidirectional: white-yellow, white-red, yellow-red, green-yellow.
  5. Elevated Runway Threshold/end, displaced threshold, non-precision IFR runways (L-861E(L))
    - i. Bidirectional: red-green, red-red

- ii. Unidirectional: green.
- 6. Elevated Runway Threshold/End, Non-precision IFR Runways (L-861SE(L))
  - i. Bidirectional: red-green
  - ii. Unidirectional: green
- 7. Elevated Runway edge, threshold, displaced threshold, precision IFR runways (L-862(L))
  - i. Bidirectional: white-white, white-yellow, white-red, green-yellow, red-yellow
- 8. Elevated Runway threshold/end, displaced threshold, precision IFR runways (L-862E(L))
  - i. Bidirectional: red-green, red-red
  - ii. Unidirectional: green
  - iii. Unidirectional: red
- H. Airfield Taxiway Lights
  - 1. In-pavement Taxiway edge, Apron edge (L-852T(L)):
    - i. Omnidirectional: blue
  - 2. In-pavement Runway Guard Light (L-852G(L))
    - i. Unidirectional (wide beam): yellow; alternately flashing
  - 3. Elevated Taxiway edge, Apron edge (L-861T)
    - i. Omnidirectional: blue
  - 4. Elevated Runway Guard Light (L-804(L))
    - i. Unidirectional: yellow; alternately flashing
- I. Obstruction Light
  - 1. Single Fixture Obstruction Light (L-810(L))
  - 2. Dual Fixture Obstruction Light (L-810(L))
- J. Retroreflective Taxiway Edge Markers

1. 30-inch post, asphalt mount: blue
2. 30-inch post, concrete mount: blue

10.2 GENERAL SPECIFICATIONS - In addition to the Specifications listed herein, the following requirements shall form a part of the specifications:

- A. Signs
  1. All products offered shall meet United States FAA Advisory Circular, AC 150/5345-44L, or updated requirements.
  2. Replacement signs shall be ADB Safegate, or approved equal
  3. Sign layout and details will be specified upon placement of order by the State Airfield Operation Personnel.
- B. Sign Panels
  1. All products offered shall meet United States FAA Advisory Circular, AC 150/5345-44L, or updated requirements.
  2. Replacement sign panels shall be ADB Safegate, or Lumacurve replacement sign panels, or approved equal.
  3. Sign layout will be specified upon placement of order by the State Airfield Operation Personnel.
  4. Size 3 sign panels shall be of the following types:
    - a. Direction, Destination, Boundary Signs (Type L-858Y).
    - b. Mandatory Instruction Signs (Type L-858R).
    - c. Runway Taxiway Location Signs (Type L-858L).
  5. Size 4 sign panels shall be Runway Distance Remaining Signs (Type L-858L).
- C. LED Sign Light Engine Retrofit Kit shall be genuine ADB Safegate replacement parts, or approved equal, designed for use and compatibility with ADB Safegate Sign Systems.
- D. Plastic Panel Dividers shall be designed for use and compatibility with ADB Safegate, or Lumacurve sign systems.
- E. Airfield Lighting
  1. All products offered shall meet United States FAA Advisory Circular, AC 150/5345-46F, or updated requirements.

2. All products offered shall meet United States FAA Advisory Circular, AC 150/5345-53D, and the latest AC 150/5345-53D Addendum, or updated requirements.
3. Airfield lighting shall be Class 2 or otherwise specified by the State Project Manager.
4. Airfield lighting mode shall be either Mode 1 or Mode 2, depending on airport that the lighting will be installed.
5. Airfield lighting Style shall be 3 or otherwise specified by the State Project Manager.
6. Airfield lighting, except for the L-850F LAHSO light, shall be LED or otherwise specified by the State Project Manager.
7. Obstruction lights shall be 120-240 VAC or 12-48 VDC depending on specific installation.

F. Taxiway Retroreflective Markers

1. All products offered shall meet United States FAA Advisory Circular, AC 150/5345-39E, or updated requirements.
2. Markers shall be Type II, elevated marker and Style II, non-plowable.

G. Substitution requests and samples shall be submitted for approval to the Project Manager prior to the contract bid date. Three (3) full size samples of each line item requested shall be submitted. No compensation will be made for the test samples and the samples shall be held by the State for product comparison in the event that the contractor is the successful bidder.

H. Delivery

1. **Products** furnished under these specifications shall be delivered within **120 calendar days** after receipt of order. If product is not able to be delivered within the specified time, it must be communicated to the Project Manager at the time the order is placed (see section A, delivery extension.) Contractor may coordinate a delivery schedule with Project Manager satisfactory to both Airport and Contractor.
2. Prior to delivery, Contractor must contact the State representative at the delivery location to coordinate delivery arrangements.

3. Delivery Location(s):
- a. Ellison Onizuka Kona International Airport at Keahole  
Airport Maintenance  
Ellison Onizuka Kona International Airport at Keahole  
73-200 Kupipi Street  
Kailua-Kona, Hawaii 96740  
Contact: Ben Aragon (808-327-9507)  
or
  - b. Hilo International Airport  
Airport Maintenance  
Hilo International Airport  
Hilo, Hawaii 96720  
Contact: Calvin Shimizu (808-961-9377)  
or
  - c. Lihue Airport  
Airport Maintenance  
3690 Ahukini Road  
Lihue, Hawaii 96766  
Contact: Sheldon Moniz (808-241-3919)  
or
  - d. Kahului Airport  
Kahului Airport Maintenance Baseyard  
Corner of Keolani Place and Aalele St.  
Kahului, Hawaii 96732  
Contact: Karl Amoral (808-250-1219)  
or
  - e. Molokai Airport  
Airport Maintenance  
3980 Airport Loop  
Ho'olehua, Hawaii 96729  
Contact: Antone Kalilikane  
(808-281-9898)  
or
  - f. Lanai Airport  
Airport Maintenance  
Lanai Ave  
Lanai City, Hawaii 96763  
Contact: Alan Fernandez (808-281-9899)  
or

g. Kalaeloa Airport (JRF)  
Airport Maintenance  
300 Midway Street  
Kapolei, Hawaii 96707  
Contact: Anna Metcalf (808-269-0377)  
or

h. Airport Division - Baseyard  
Daniel K. Inouye International Airport  
2919 Aolele Street  
Honolulu, Hawaii 96819  
Contact: Alex Tamoria (808-836-6481)

I. Delivery Extension:

1. Contractor shall not be held responsible for delay due to reasons beyond his control, provided that prior to the delivery deadline, he/she notifies the State Project Manager of such delay and the reasons for such delay and request an extension of delivery time.
2. REQUEST FOR EXTENTIONS WILL NOT BE CONSIDERED WITHOUT A COPY OF THE FACTORY ORDER AND A COPY OF THE FACTORY CONFIRMATION OF THE ORDER AND WITHOUT DOCUMENTS SUBSTANTIATING THAT THE CAUSE(S) FOR DELAY IS, IN FACT, BEYOND THE CONTROL OF THE CONTRACTOR. The State shall be the sole judge of whether such delay is truly beyond the control of the Contractor and whether an extension will be granted.

J. Invoicing:

1. Contractor shall submit original of the invoice to the delivery address.
2. Invoice shall reference the contract number and delivery date.

10.3 ORDERS - Orders shall be issued on an as needed basis during the contract period. The State shall not issue, and the Contractor shall not accept any orders after the contract expiration date. However, the Contractor shall be obligated to fill timely orders for which delivery may be extended beyond the contract expiration date for reasons beyond the Contractor's control (see Section 10.2.D.)

10.4 UNIT PRICES - Unit prices on the bid proposal to the State shall remain firm for the entire thirty-six (36) months of this contract. **Unit prices shall include all shipping, taxes and applicable fees.**

10.5 LIQUIDATED DAMAGES - Liquidated damages of \$200.00 per calendar day shall be assess for each day beyond the specified 120 calendar day delivery period unless granted a delivery extension.

10.6 TERM OF CONTRACT - The term of this contract shall be for a period of thirty-six (36) months from the date of the official Notice to Proceed issued by the State.

STATE OF HAWAII  
DEPARTMENT OF TRANSPORTATION  
HONOLULU, HAWAII

PROPOSAL

PROPOSAL TO THE STATE OF HAWAII  
DEPARTMENT OF TRANSPORTATION  
AIRPORTS

PROJECT: AIRFIELD SIGN PANELS, LIGHTING, &  
RETROFIT  
STATEWIDE

PROJECT NO.: BS1521-53R

TERM OF CONTRACT: 36 MONTHS from the date indicated  
in the Notice to Proceed from the  
Department of Transportation

LIQUIDATED DAMAGES: TWO HUNDRED DOLLARS (\$200.00) per  
calendar day shall be assessed for  
each day beyond the specified 120  
calendar day delivery period unless  
granted a delivery extension.

PROJECT MANAGER: Maybelle Lee  
Department of Transportation,  
Airports Division  
Statewide, Engineering  
E-mail: maybelle.p.lee@hawaii.gov  
Ph.: 808-838-8890

ELECTRONIC SUBMITTAL: Bidders shall submit and upload the  
complete proposal to HIePRO prior  
to the bid opening date and time.  
Any additional support documents  
explicitly designated as  
confidential and/or proprietary  
shall be uploaded as a separate  
file to HIePRO. See SPECIAL  
PROVISIONS 2.3 DELIVERY OF  
PROPOSALS for complete details.  
FAILURE TO UPLOAD THE COMPLETE  
PROPOSAL TO HIePRO SHALL BE GROUNDS  
FOR REJECTION OF THE BID

Director of Transportation  
Aliiaimoku Hale  
869 Punchbowl Street  
Honolulu, Hawaii 96813

Dear Sir:

The undersigned bidder declares the following:

1. It has not, either directly or indirectly, entered into any agreement, participated in any collusion, or otherwise taken any action in restraint of free competitive bidding in connection with this proposal.
2. It has not been assisted or represented on this matter by any individual who has, in a State capacity, been involved in the subject matter of this contract within the past two years.
3. It has not and will not, either directly or indirectly offered or given a gratuity (i.e. an entertainment or gift) to any State or County employee to obtain a contract or favorable treatment under a contract.

The undersigned bidder further agrees to the following:

1. If this proposal is accepted, it shall execute a contract with the Department to provide all necessary labor, machinery, tools, equipment, apparatus and any other means of construction, to do all the work and to furnish all the materials specified in the contract in the manner and within the time therein prescribed in the contract, and that it shall accept in full payment therefore the sum of the unit and/or lump sum prices as set forth in the attached proposal schedule for the actual quantities of work performed and materials furnished and furnish satisfactory security in accordance with Section 103D-324, Hawaii Revised Statutes, within 10 days after the award of the contract or within such time as the Director of Transportation may allow after the undersigned has received the contract documents for execution, and is fully aware that non-compliance with the aforementioned terms will result in the forfeiture of the full amount of the bid guarantee required under Section 103D-323, Hawaii Revised Statutes.

Matls. & Serv.  
r12/2020

2. That the quantities given in the attached proposal schedule are approximate only and are intended principally to serve as a guide in determining and comparing the bids.
3. That the Department does not either expressly or by implication, agree that the actual amount of work will correspond therewith, but reserves the right to increase or decrease the amount of any class or portion of the work, or to omit portions of the work, as may be deemed necessary or advisable by the Director of Transportation, and that all increased or decreased quantities of work shall be performed at the unit prices set forth in the attached proposal schedule except as provided for in the specifications.
4. In case of a discrepancy between unit prices and the totals in said Proposal Schedule, the unit prices shall prevail.
5. Agrees to begin work within 10 working days after the date of notification to commence with the work, which date is in the notice to proceed, and shall finish the entire project within the time prescribed.
6. The Director of Transportation reserves the right to reject any or all bids and to waive any defects when in the Director's opinion such rejections or waiver will be for the best interest of the public.

Receipt is hereby acknowledged and complete examination is hereby expressly guaranteed of the following listed items: the specifications, the notice to bidders, the special provisions, if any, the proposal, the plans, if any, and the contract form.

The undersigned acknowledges receipt of any addendum, issued by recording in the space below the date of receipt.

Addendum No. 1 \_\_\_\_\_ Addendum No. 3 \_\_\_\_\_

Addendum No. 2 \_\_\_\_\_ Addendum No. 4 \_\_\_\_\_

The undersigned hereby certifies that the bid prices contained in the attached proposal schedule have been carefully checked and are submitted as correct, final and are net prices.

\_\_\_\_\_  
Bidder (Company Name)

By \_\_\_\_\_  
Authorized Signature

\_\_\_\_\_  
Print Name and Title

\_\_\_\_\_  
Business Address

\_\_\_\_\_  
Business Telephone

\_\_\_\_\_  
Date

\_\_\_\_\_  
Contact Person (If different from above)

Phone: \_\_\_\_\_ Email: \_\_\_\_\_

\*Hawaii General Excise Tax License No. \_\_\_\_\_

NOTE:

If bidder is a CORPORATION, the legal name of the corporation shall be set forth above, the corporate seal affixed, together with the signature(s) of the officer(s) authorized to sign contracts on behalf of the corporation. Please attach to this page current (not more than six months old) evidence of the authority of the officer(s) to sign on behalf of the corporation.

If bidder is a PARTNERSHIP, the true name of the partnership shall be set forth above with the signature(s) of the general partner(s) authorized to sign contracts on behalf of the partnership. Please attach to this page current (not more than six months old) evidence of the authority of the partner(s) to sign on behalf of the partnership.

If bidder is an INDIVIDUAL, the bidder's signature shall be placed in the space provided therefore on page PF-4.

If signature is by an agent, other than an officer of a corporation or a partner of a partnership, a POWER OF ATTORNEY must be on file with the Department prior to the opening of bids or submitted with the bid; otherwise, the bid may be rejected as irregular and unauthorized.

\*Bidder will be considered an out-of-state vendor if Hawaii General Excise Tax License No. is not indicated. See Section 2.8 Out-of-State Bidders of the Specifications.

AIRFIELD SIGN PANELS, LIGHTING, & RETROFIT

STATEWIDE

PROJECT NO. BS1521-53R

PROPOSAL SCHEDULE

| Item No.                       | Description   | Qty. | Unit | Unit Price    | Total    |
|--------------------------------|---|------|------|---------------|----------|
| <b>Replacement Signs</b>       |   |      |      |               |          |
| 10.1-A1.1                      | Size 3, 1 Module Sign<br>(Order Quantity 1-30 Signs)<br>(ADB Safegate or equivalent)            | 1    | Each | \$ _____ /Ea. | \$ _____ |
| 10.1-A2.1                      | Size 3, 2 Module Sign<br>(Order Quantity 1-30 Signs)<br>(ADB Safegate or equivalent)            | 1    | Each | \$ _____ /Ea. | \$ _____ |
| 10.1-A3.1                      | Size 3, 3 Module Sign<br>(Order Quantity 1-30 Signs)<br>(ADB Safegate or equivalent)            | 1    | Each | \$ _____ /Ea. | \$ _____ |
| 10.1-A4.1                      | Size 3, 4 Module Sign<br>(Order Quantity 1-30 Signs)<br>(ADB Safegate or equivalent)            | 1    | Each | \$ _____ /Ea. | \$ _____ |
| 10.1-A5.1                      | Size 4, 1 Module Sign<br>(Order Quantity 1-30 Signs)<br>(ADB Safegate or equivalent)            | 1    | Each | \$ _____ /Ea. | \$ _____ |
| <b>Replacement Sign Panels</b> |   |      |      |               |          |
| 10.1-B1.1                      | Size 3, 1 Module Sign Panel<br>(Order Quantity 1-10 Panels)<br>(Lumacurve or equivalent)        | 1    | Each | \$ _____ /Ea. | \$ _____ |
| 10.1-B1.2                      | Size 3, 1 Module Sign Panel<br>(Order Quantity 11-50 Panels)<br>(Lumacurve or equivalent)       | 11   | Each | \$ _____ /Ea. | \$ _____ |
| 10.1-B2.1                      | Size 3, 1 Module Blank Sign Panel<br>(Order Quantity 1-10 Panels)<br>(Lumacurve or equivalent)  | 1    | Each | \$ _____ /Ea. | \$ _____ |
| 10.1-B2.2                      | Size 3, 1 Module Blank Sign Panel<br>(Order Quantity 11-50 Panels)<br>(Lumacurve or equivalent) | 11   | Each | \$ _____ /Ea. | \$ _____ |
| 10.1-B3.1                      | Size 4, 1 Module Sign Panel<br>(Order Qty. 1-10 Panels)<br>(Lumacurve or equivalent)            | 1    | Each | \$ _____ /Ea. | \$ _____ |
| 10.1-B3.2                      | Size 4, 1 Module Sign Panel<br>(Order Qty. 11-50 Panels)<br>(Lumacurve or equivalent)           | 11   | Each | \$ _____ /Ea. | \$ _____ |

AIRFIELD SIGN PANELS, LIGHTING, & RETROFIT

STATEWIDE

PROJECT NO. BS1521-53R

PROPOSAL SCHEDULE

| Item No.                            | Description  | Qty. | Unit | Unit Price    | Total    |
|-------------------------------------|--|------|------|---------------|----------|
| Replacement Sign Panels (continued) |  |      |      |               |          |
| 10.1-C1.1                           | Size 3, 1 Module Sign Panel<br>(Order Quantity 1-10 Panels)<br>(ADB Safegate or equivalent)        | 1    | Each | \$ _____ /Ea. | \$ _____ |
| 10.1-C1.2                           | Size 3, 1 Module Sign Panel<br>(Order Quantity 11-50 Panels)<br>(ADB Safegate or equivalent)       | 11   | Each | \$ _____ /Ea. | \$ _____ |
| 10.1-C1.3                           | Size 3, 1 Module Sign Panel<br>(Order Quantity 51-100+ Panels)<br>(ADB Safegate or equivalent)     | 51   | Each | \$ _____ /Ea. | \$ _____ |
| 10.1-C2.1                           | Size 3, 2 Module Sign Panel<br>(Order Quantity 1-10 Panels)<br>(ADB Safegate or equivalent)        | 1    | Each | \$ _____ /Ea. | \$ _____ |
| 10.1-C2.2                           | Size 3, 2 Module Sign Panel<br>(Order Quantity 11-50 Panels)<br>(ADB Safegate or equivalent)       | 11   | Each | \$ _____ /Ea. | \$ _____ |
| 10.1-C2.3                           | Size 3, 2 Module Sign Panel<br>(Order Quantity 51-100+ Panels)<br>(ADB Safegate or equivalent)     | 51   | Each | \$ _____ /Ea. | \$ _____ |
| 10.1-C3.1                           | Size 3, 1 Module Blank Sign Panel<br>(Order Quantity 1-10 Panels)<br>(ADB Safegate or equivalent)  | 1    | Each | \$ _____ /Ea. | \$ _____ |
| 10.1-C3.2                           | Size 3, 1 Module Blank Sign Panel<br>(Order Quantity 11-50 Panels)<br>(ADB Safegate or equivalent) | 11   | Each | \$ _____ /Ea. | \$ _____ |
| 10.1-C4.1                           | Size 3, 2 Module Blank Sign Panel<br>(Order Quantity 1-10 Panels)<br>(ADB Safegate or equivalent)  | 1    | Each | \$ _____ /Ea. | \$ _____ |
| 10.1-C4.2                           | Size 3, 2 Module Blank Sign Panel<br>(Order Quantity 11-50 Panels)<br>(ADB Safegate or equivalent) | 11   | Each | \$ _____ /Ea. | \$ _____ |
| 10.1-C5.1                           | Size 4, 1 Module Sign Panel<br>(Order Qty. 1-10 Panels)<br>(ADB Safegate or equivalent)            | 1    | Each | \$ _____ /Ea. | \$ _____ |
| 10.1-C5.2                           | Size 4, 1 Module Sign Panel<br>(Order Qty. 11- 50 Panels)<br>(ADB Safegate or equivalent)          | 11   | Each | \$ _____ /Ea. | \$ _____ |

AIRFIELD SIGN PANELS, LIGHTING, & RETROFIT

STATEWIDE

PROJECT NO. BS1521-53R

PROPOSAL SCHEDULE

| Item No.                           | Description  | Qty. | Unit | Unit Price    | Total    |
|------------------------------------|--|------|------|---------------|----------|
| LED Sign Light Engine Retrofit Kit |  |      |      |               |          |
| 10.1-D1.1                          | Size 3, 1 Module LED Retrofit Kit<br>(Order Quantity 1-10 Kits)<br>(ADB Safegate or equivalent)  | 1    | Each | \$ _____ /Ea. | \$ _____ |
| 10.1-D1.2                          | Size 3, 1 Module LED Retrofit Kit<br>(Order Quantity 11-50 Kits)<br>(ADB Safegate or equivalent) | 11   | Each | \$ _____ /Ea. | \$ _____ |
| 10.1-D2.1                          | Size 3, 2 Module LED Retrofit Kit<br>(Order Quantity 1-10 Kits)<br>(ADB Safegate or equivalent)  | 1    | Each | \$ _____ /Ea. | \$ _____ |
| 10.1-D2.2                          | Size 3, 2 Module LED Retrofit Kit<br>(Order Quantity 11-50 Kits)<br>(ADB Safegate or equivalent) | 11   | Each | \$ _____ /Ea. | \$ _____ |
| 10.1-D3.1                          | Size 3, 3 Module LED Retrofit Kit<br>(Order Quantity 1-10 Kits)<br>(ADB Safegate or equivalent)  | 1    | Each | \$ _____ /Ea. | \$ _____ |
| 10.1-D3.2                          | Size 3, 3 Module LED Retrofit Kit<br>(Order Quantity 11-50 Kits)<br>(ADB Safegate or equivalent) | 11   | Each | \$ _____ /Ea. | \$ _____ |
| 10.1-D4.1                          | Size 3, 4 Module LED Retrofit Kit<br>(Order Quantity 1-10 Kits)<br>(ADB Safegate or equivalent)  | 1    | Each | \$ _____ /Ea. | \$ _____ |
| 10.1-D4.2                          | Size 3, 4 Module LED Retrofit Kit<br>(Order Quantity 11-50 Kits)<br>(ADB Safegate or equivalent) | 11   | Each | \$ _____ /Ea. | \$ _____ |
| 10.1-D5.1                          | Size 4, 1 Module LED Retrofit Kit<br>(Order Quantity 1-10 Kits)<br>(ADB Safegate or equivalent)  | 1    | Each | \$ _____ /Ea. | \$ _____ |
| 10.1-D5.2                          | Size 4, 1 Module LED Retrofit Kit<br>(Order Quantity 11-50 Kits)<br>(ADB Safegate or equivalent) | 11   | Each | \$ _____ /Ea. | \$ _____ |

AIRFIELD SIGN PANELS, LIGHTING, & RETROFIT

STATEWIDE

PROJECT NO. BS1521-53R

PROPOSAL SCHEDULE

| Item No.                      | Description  | Qty. | Unit | Unit Price    | Total    |
|-------------------------------|--|------|------|---------------|----------|
| <b>Plastic Panel Divider</b>  |  |      |      |               |          |
| 10.1-E1.1                     | Size 3 Plastic Panel Divider<br>(Order Quantity 1-50)<br>(ADB Safegate or equivalent)  | 1    | Each | \$ _____ /Ea. | \$ _____ |
| 10.1-F1.1                     | Size 3 Plastic Panel Divider<br>(Order Quantity 1-50)<br>(Lumacurve or equivalent)   | 1    | Each | \$ _____ /Ea. | \$ _____ |
| <b>Airfield Runway Lights</b> |  |      |      |               |          |
| 10.1-G1.1                     | Runway Edge, displaced threshold<br>(L-850C(L)) (Bidirectional)<br>(Order Quantity 1-30)   | 1    | Each | \$ _____ /Ea. | \$ _____ |
| 10.1-G2.1                     | Runway Threshold/end<br>(L-850D(L)) (Bidirectional)<br>(Order Quantity 1-30)   | 1    | Each | \$ _____ /Ea. | \$ _____ |
| 10.1-G2.2                     | Runway Threshold/end<br>(L-850D(L)) (Unidirectional)<br>(Order Quantity 1-10)  | 1    | Each | \$ _____ /Ea. | \$ _____ |
| 10.1-G3.1                     | LAHSO (L-850F) (Unidirectional)<br>(Order Quantity 1-10)   | 1    | Each | \$ _____ /Ea. | \$ _____ |
| 10.1-G4.1                     | Runway Edge, Non-precision<br>Instrument Flight Rules (IFR)<br>runways, displaced threshold<br>(L-861(L)) (Omnidirectional)<br>(Order Quantity 1-25)   | 1    | Each | \$ _____ /Ea. | \$ _____ |
| 10.1-G4.2                     | Runway Edge, Non-precision<br>Instrument Flight Rules (IFR)<br>runways, displaced threshold<br>(L-861(L)) (Omnidirectional)<br>(Order Quantity 26-100) | 26   | Each | \$ _____ /Ea. | \$ _____ |
| 10.1-G4.3                     | Runway Edge, Non-precision<br>Instrument Flight Rules (IFR)<br>runways, displaced threshold<br>(L-861(L)) (Bidirectional)<br>(Order Quantity 1-25)     | 1    | Each | \$ _____ /Ea. | \$ _____ |
| 10.1-G4.4                     | Runway Edge, Non-precision<br>Instrument Flight Rules (IFR)<br>runways, displaced threshold<br>(L-861(L)) (Bidirectional)<br>(Order Quantity 26-100)   | 26   | Each | \$ _____ /Ea. | \$ _____ |

AIRFIELD SIGN PANELS, LIGHTING, & RETROFIT

STATEWIDE

PROJECT NO. BS1521-53R

PROPOSAL SCHEDULE

| Item No.                           | Description  | Qty. | Unit | Unit Price    | Total    |
|------------------------------------|--|------|------|---------------|----------|
| Airfield Runway Lights (continued) |  |      |      |               |          |
| 10.1-G5.1                          | Runway Threshold/end, displaced threshold, non-precision IFR runways (L-861E(L)) (Bidirectional)<br>(Order Quantity 1-30)  | 1    | Each | \$ _____ /Ea. | \$ _____ |
| 10.1-G5.2                          | Runway Threshold/end, displaced threshold, non-precision IFR runways (L-861E(L)) (Unidirectional)<br>(Order Quantity 1-10) | 1    | Each | \$ _____ /Ea. | \$ _____ |
| 10.1-G6.1                          | Runway Threshold/end, Non-precision IFR runways (L-861SE(L)) (Bidirectional)<br>(Order Quantity 1-30)                      | 1    | Each | \$ _____ /Ea. | \$ _____ |
| 10.1-G6.2                          | Runway Threshold/end, Non-precision IFR runways (L-861SE(L)) (Unidirectional)<br>(Order Quantity 1-10)                     | 1    | Each | \$ _____ /Ea. | \$ _____ |
| 10.1-G7.1                          | Runway edge, threshold, displaced threshold, precision IFR runways (L-862(L)) (Bidirectional)<br>(Order Quantity 1-25)     | 1    | Each | \$ _____ /Ea. | \$ _____ |
| 10.1-G7.2                          | Runway edge, threshold, displaced threshold, precision IFR runways (L-862(L)) (Bidirectional)<br>(Order Quantity 26-100)   | 26   | Each | \$ _____ /Ea. | \$ _____ |
| 10.1-G8.1                          | Runway threshold/end, displaced threshold, precision IFR runways (L-862E(L)) (Bidirectional)<br>(Order Quantity 1-30)      | 1    | Each | \$ _____ /Ea. | \$ _____ |
| 10.1-G8.2                          | Runway threshold/end, displaced threshold, precision IFR runways (L-862E(L)) (Unidirectional)<br>(Order Quantity 1-10)     | 1    | Each | \$ _____ /Ea. | \$ _____ |

AIRFIELD SIGN PANELS, LIGHTING, & RETROFIT

STATEWIDE

PROJECT NO. BS1521-53R

PROPOSAL SCHEDULE

| Item No.   | Description  | Qty.     | Unit | Unit Price    | Total    |
|--|--|----------|------|---------------|----------|
| <b>Airfield Taxiway Lights</b>                       |  |          |      |               |          |
| 10.1-H1.1  | Taxiway edge, Apron edge L-852T(L)<br>(Omnidirectional)<br>(Order Quantity 1-25)                   | 1        | Each | \$ _____ /Ea. | \$ _____ |
| 10.1-H1.2  | Taxiway edge, Apron edge L-852T(L)<br>(Omnidirectional)<br>(Order Quantity 26-100)                 | 26       | Each | \$ _____ /Ea. | \$ _____ |
| 10.1-H2.1  | Runway Guard Light (L-852G(L))<br>(Unidirectional)<br>(Order Quantity 1-25)                        | 1        | Each | \$ _____ /Ea. | \$ _____ |
| 10.1-H3.1  | Taxiway edge, Apron edge (L-861T(L)) (Omnidirectional)<br>(Order Quantity 1-25)                    | 1        | Each | \$ _____ /Ea. | \$ _____ |
| 10.1-H3.2  | Taxiway edge, Apron edge (L-861T(L)) (Omnidirectional)<br>(Order Quantity 26-100)                  | 26       | Each | \$ _____ /Ea. | \$ _____ |
| 10.1-H4.1  | Runway Guard Light<br>(L-804(L)) (Unidirectional)<br>(Order Quantity 1-20)                         | 1        | Each | \$ _____ /Ea. | \$ _____ |
| <b>Obstruction Lights</b>                            |  |          |      |               |          |
| 10.1-I1.1  | Single Fixture Obstruction Light<br>(L-810(L)) (Order Quantity 1-10)                               | 1        | Each | \$ _____ /Ea. | \$ _____ |
| 10.1-I2.1  | Dual Fixture Obstruction Light<br>(L-810(L)) (Order Quantity 1-10)                                 | 1        | Each | \$ _____ /Ea. | \$ _____ |
| <b>Airfield Retroreflective Taxiway Edge Markers</b> |  |          |      |               |          |
| 10.1-J1.1  | Retroreflective Taxiway Edge<br>Markers (30 inch post, asphalt<br>mount)<br>(Order Quantity 1-50)  | 1        | Each | \$ _____ /Ea. | \$ _____ |
| 10.1-J2.1  | Retroreflective Taxiway Edge<br>Markers (30 inch post, concrete<br>mount)<br>(Order Quantity 1-50) | 1        | Each | \$ _____ /Ea. | \$ _____ |
| <b>TOTAL AMOUNT FOR COMPARISON OF BIDS</b>           |  | \$ _____ |      |               |          |

AIRFIELD SIGN PANELS, LIGHTING, & RETROFIT

STATEWIDE

PROJECT NO. BS1521-53R

PROPOSAL SCHEDULE

| Item No.  | Description | Qty. | Unit | Unit Price | Total |
|---|-------------|------|------|------------|-------|
| <p>The attention of out-of-state bidders is directed to Section 2.8 of the Specifications. An out-of-state bidder is required to answer the following statement:</p> <p>State of Hawaii General Excise and Use Taxes are included in all bid prices.</p> <p style="text-align: center;"><u>Write "Yes" or "No"</u></p> <p>If the above statement is left unanswered, it will be considered a "No" answer by the State.</p>  |             |      |      |            |       |
| <p>Notes:</p> <ol style="list-style-type: none"> <li>Bids shall include all Federal, State, County and other applicable taxes and fees.</li> <li>The TOTAL AMOUNT FOR COMPARISON OF BIDS will be used to determine the lowest reasonable bidder.</li> <li>Bidders must complete all unit prices and amounts. Failure to do so may be grounds for rejection of bid.</li> <li>If a discrepancy occurs between unit bid price and the bid price, the unit bid price shall govern.</li> <li>Bidders shall submit and <u>upload the complete proposal to HlePRO</u> prior to the bid opening date and time. Proposals received after said due date and time shall not be considered. Any additional support documents explicitly designated as <u>confidential and/or proprietary</u> shall be uploaded as <u>a separate file</u> to HlePRO. Bidders shall not include confidential and/or proprietary documents with the proposal. The record of each bidder and respective bid shall be open to public inspection. Original (wet ink, hard copy) proposal documents are not required to be submitted. Contract award shall be based on evaluation of proposals submitted and uploaded to HlePRO.</li> </ol> <p><u>FAILURE TO UPLOAD THE COMPLETE PROPOSAL TO HlePRO SHALL BE GROUNDS FOR REJECTION OF THE BID.</u></p> <p>If there is a conflict between the specification document and the HlePRO solicitation, the specifications shall govern and control, unless otherwise specified.</p> <ol style="list-style-type: none"> <li>The Contract shall be an indefinite quantity/"as needed" contract. Refer to Section 4.7 of the Special Provisions.</li> </ol> |             |      |      |            |       |

STATE OF HAWAII  
DEPARTMENT OF TRANSPORTATION  
HONOLULU, HAWAII

EXHIBITS

# EXHIBIT - SAMPLE SIGN INVENTORY(S)

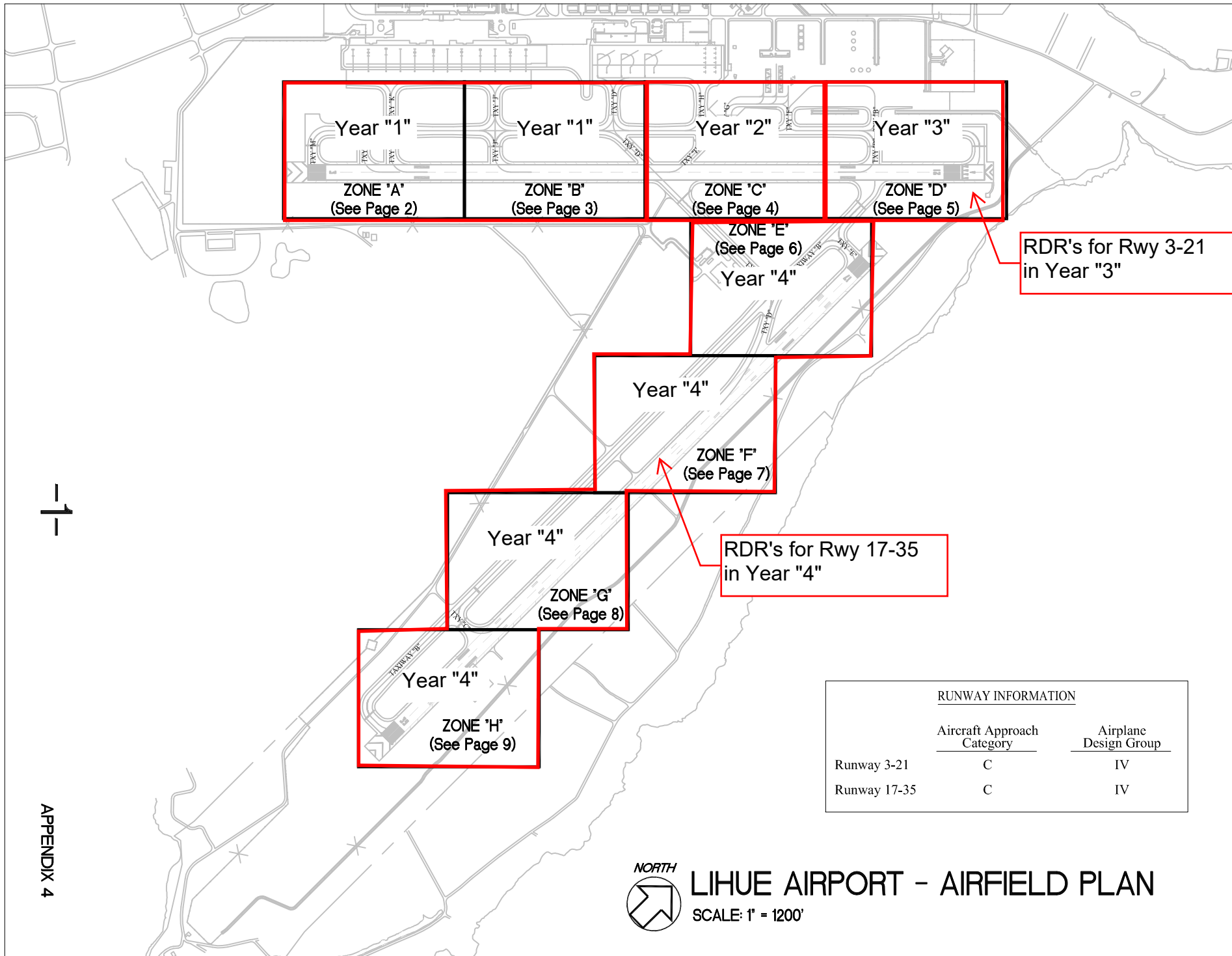

— 1 —

APPENDIX 4



**LIHUE AIRPORT - AIRFIELD PLAN**  
SCALE: 1" = 1200'

-2-

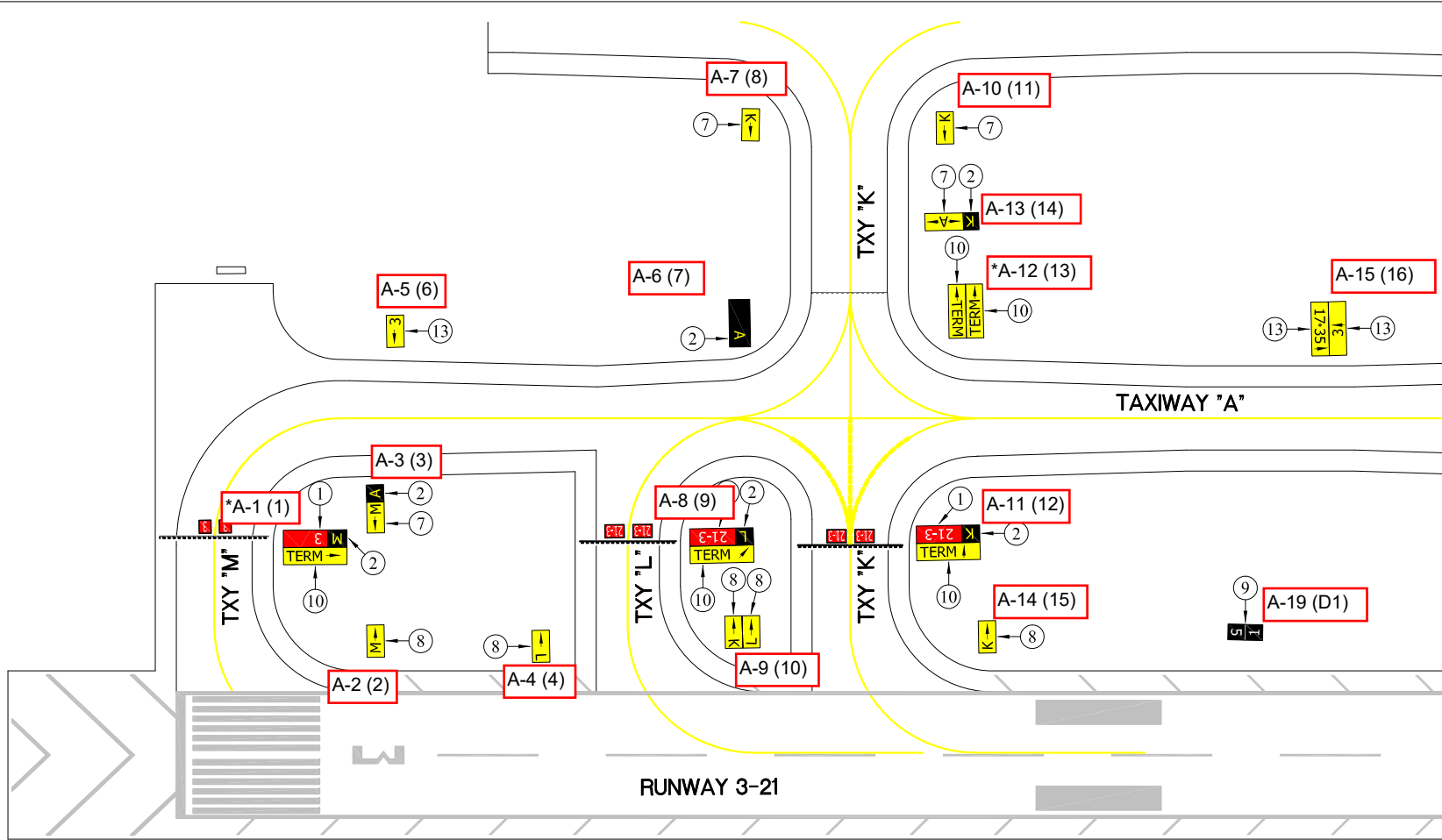

APPENDIX

A-1(1) - plan view should show a blank panel next to the 3  
 A-12 (13) - believed to have TERM on only one side of the sign



# ZONE "A" SIGN SYSTEM PLAN

NOTE: SEE PAGE 10 FOR LEGEND

**Map A Totals**  
 # of Signs=16  
 # of single panels = 15  
 # of double panels = 10  
 # RDR panels = 2

Note: RDR sign panels for Rwy 3-21 to be replaced in Year "3")

-3-

APPENDIX 4

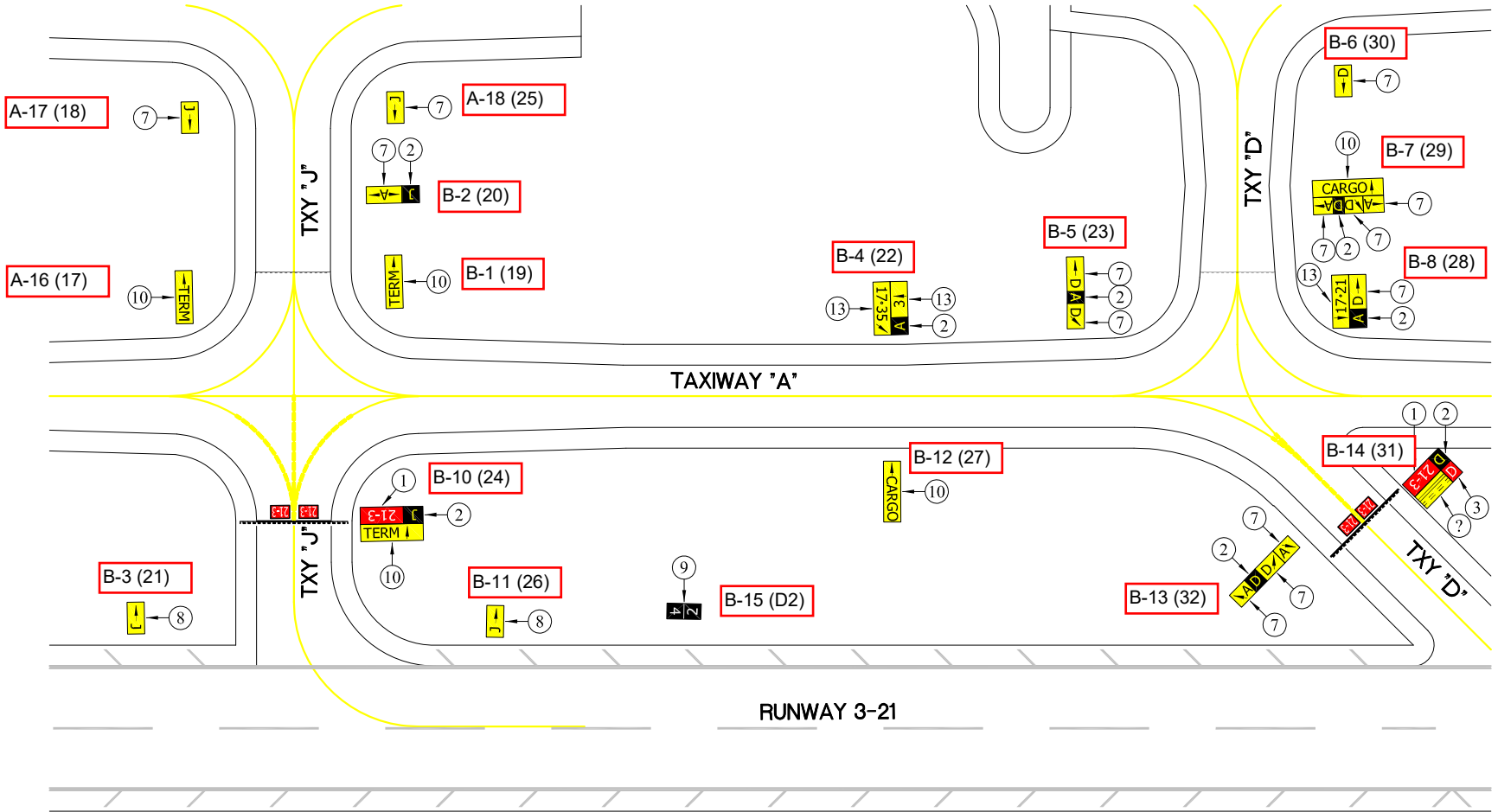

# ZONE "B" SIGN SYSTEM PLAN

NOTE: SEE PAGE 10 FOR LEGEND

**Map A Totals**  
 # of Signs=17  
 # of single panels = 15  
 # of double panels = 18  
 # RDR panels = 2

Note: RDR sign panels for Rwy 3-21 to be replaced in Year "3")

-4-

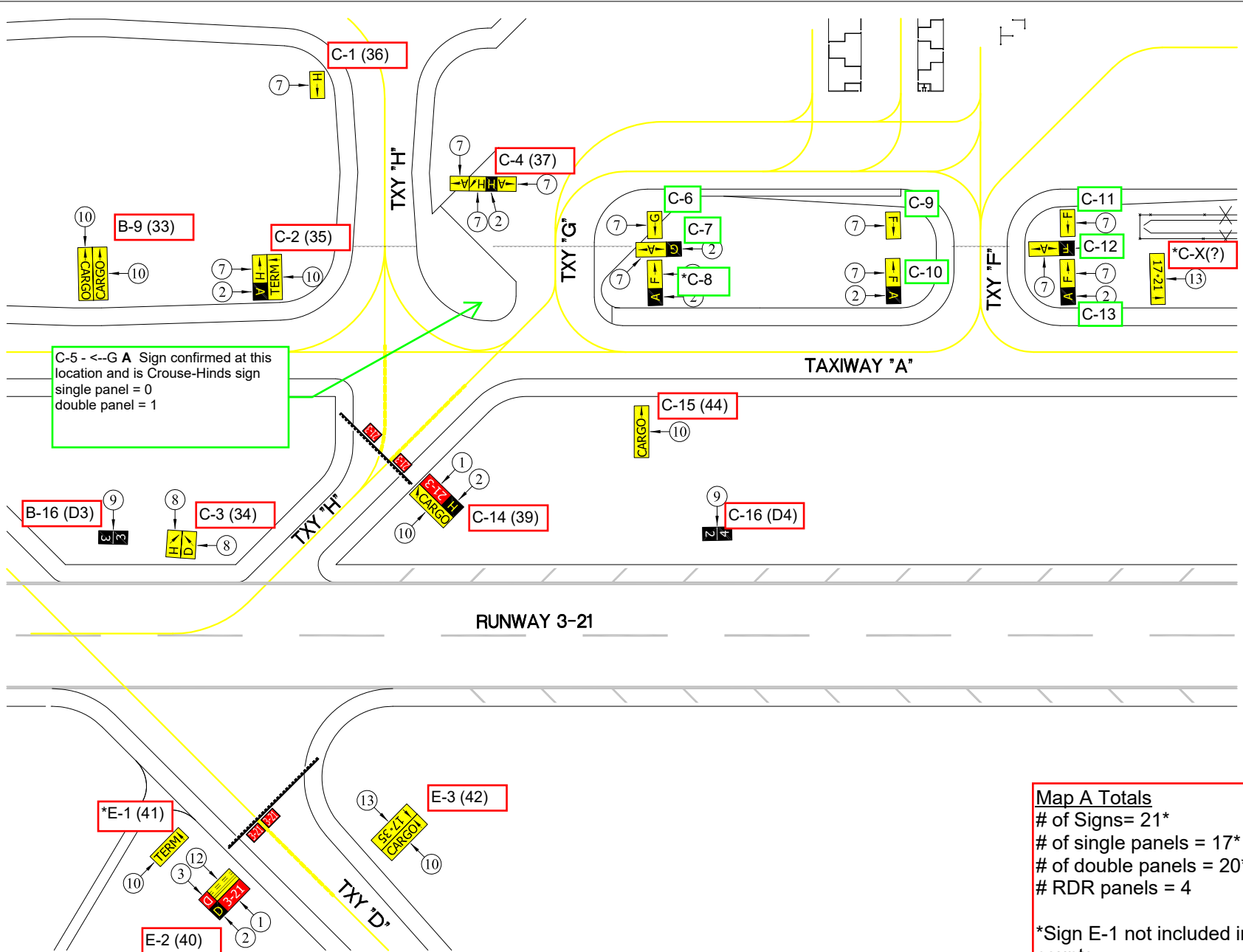

**Map A Totals**  
 # of Signs= 21\*  
 # of single panels = 17\*  
 # of double panels = 20\*  
 # RDR panels = 4

\*Sign E-1 not included in counts

Note: RDR sign panels for Rwy 3-21 to be replaced in Year "3")

\*E1 - sign not in field. Is not needed and w/in RSA. Remove from plan view. Sign E-3 provides same message  
 \*C-8 - plan view should be updated to show G instead of F  
 \*C-X(?) - sign not included in inventory spreadsheet. Assumed to be Crouse sign...needs field confirmation  
 C-5 - <-GA sign needs to be added to the plan and replaced as it is a Hart-Crouse sign



# ZONE "C" SIGN SYSTEM PLAN

NOTE: SEE PAGE 10 FOR LEGEND

APPENDIX

-5-

APPENDIX

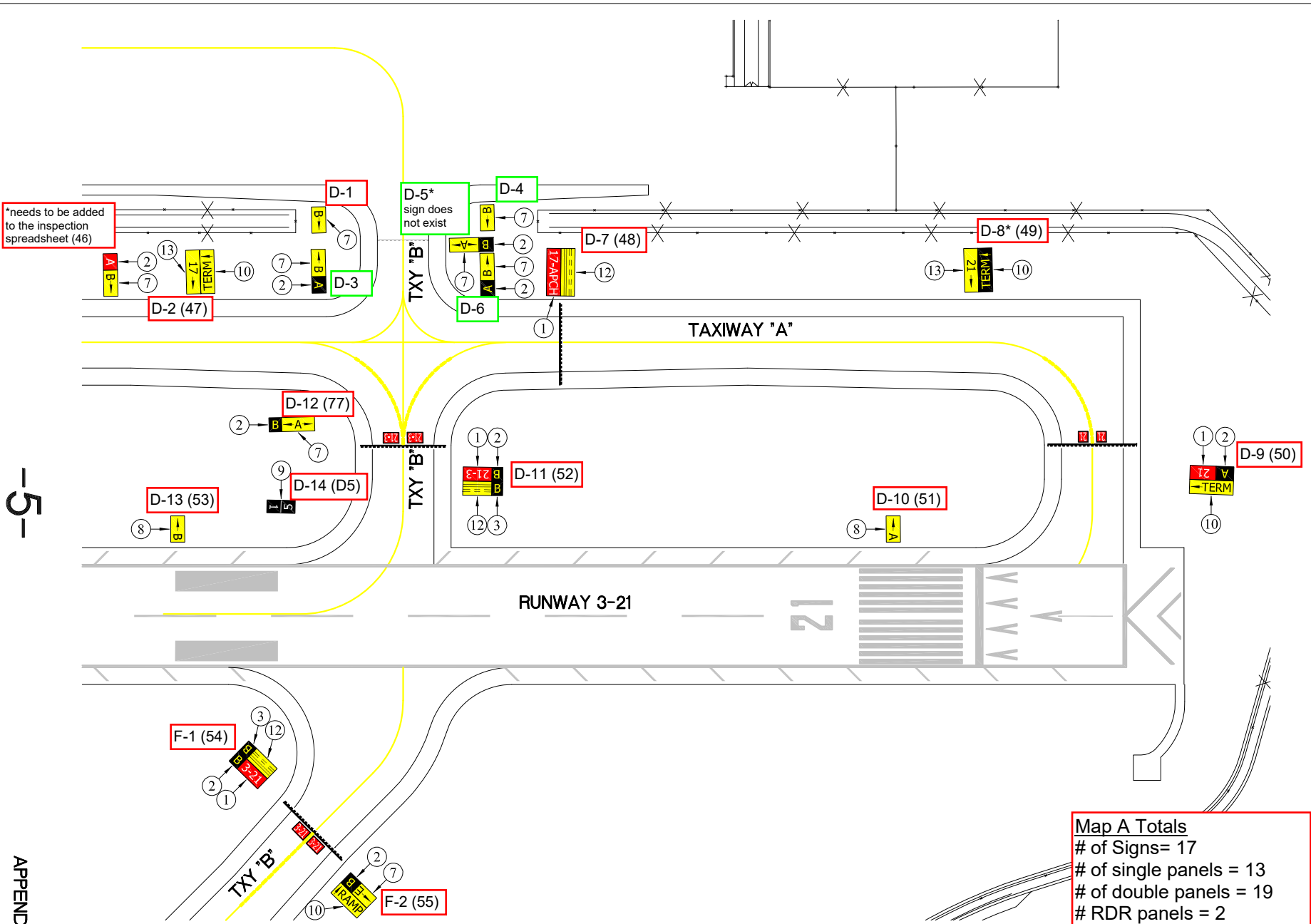

**Map A Totals**  
 # of Signs= 17  
 # of single panels = 13  
 # of double panels = 19  
 # RDR panels = 2

Note: RDR sign panels for Rwy 3-21 to be replaced in Year "3")

\*46 - Airport to provide photo of sign to determine if older Crouse-Hinds sign  
 \*D-8 - map shows black background for TERM which should be yellow



# ZONE "D" SIGN SYSTEM PLAN

NOTE: SEE PAGE 10 FOR LEGEND

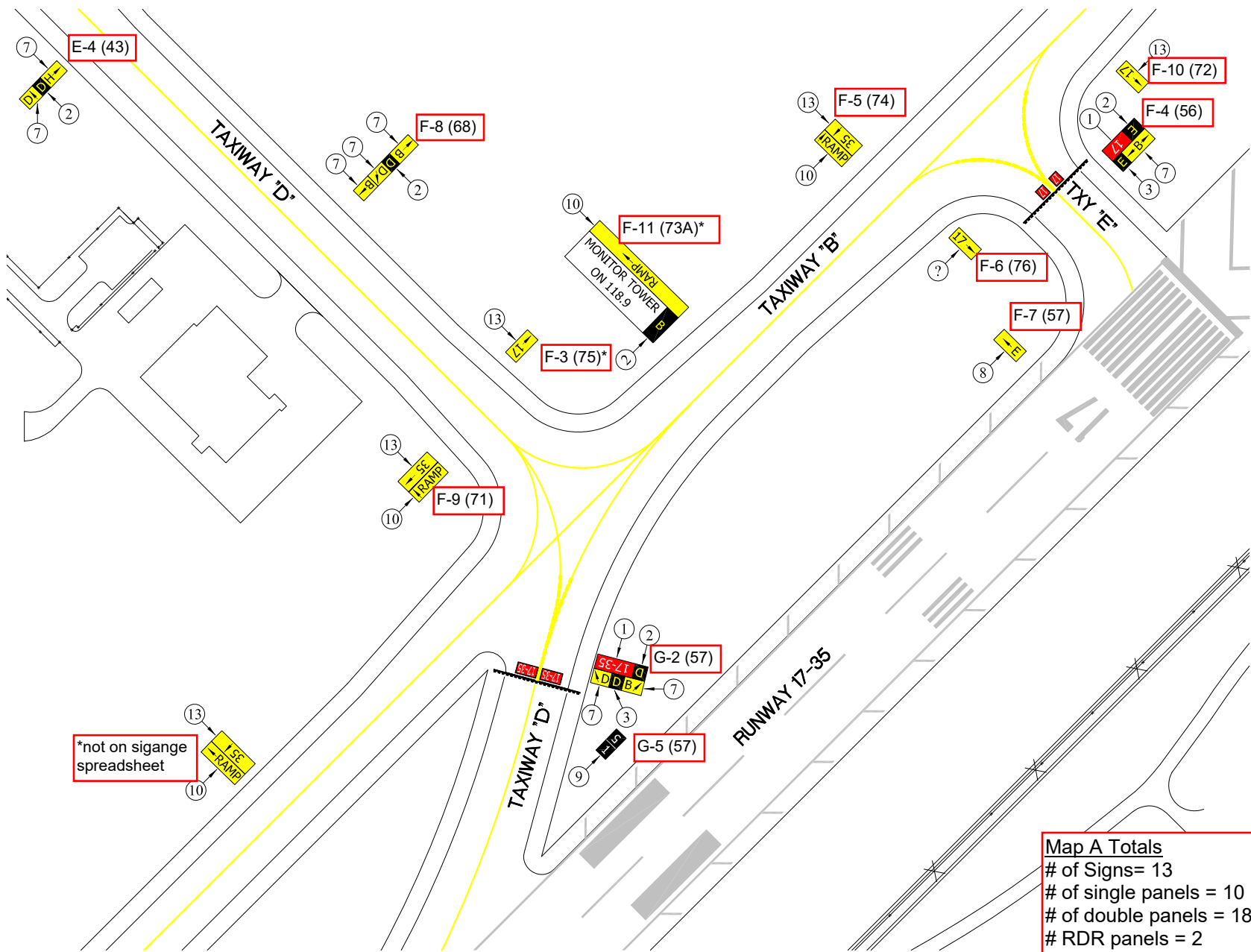

\*not on sigange spreadsheet

**Map A Totals**  
 # of Signs= 13  
 # of single panels = 10  
 # of double panels = 18  
 # RDR panels = 2

Note: RDR sign panels for Rwy 17-35 to be replaced in Year "4")

\*F-3 - inventory spreadsheet states new sign needed  
 \*F-11 - plan view needs to be updated as it doesn't match message in the field



# ZONE "E" SIGN SYSTEM PLAN

NOTE: SEE PAGE 10 FOR LEGEND

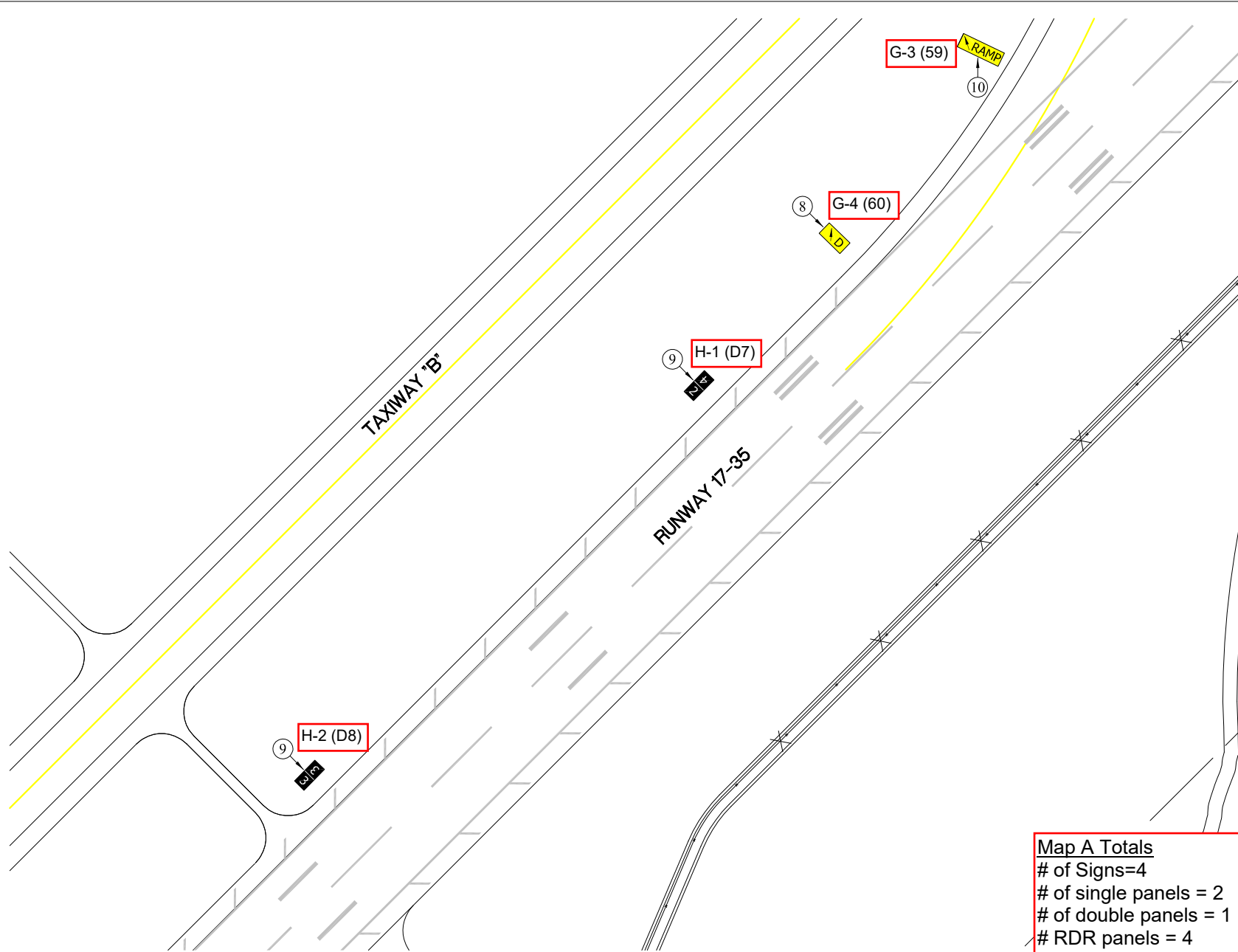

# ZONE "F" SIGN SYSTEM PLAN

NOTE: SEE PAGE 10 FOR LEGEND

**Map A Totals**  
 # of Signs=4  
 # of single panels = 2  
 # of double panels = 1  
 # RDR panels = 4

Note: RDR sign panels for Rwy 17-35 to be replaced in Year "4"

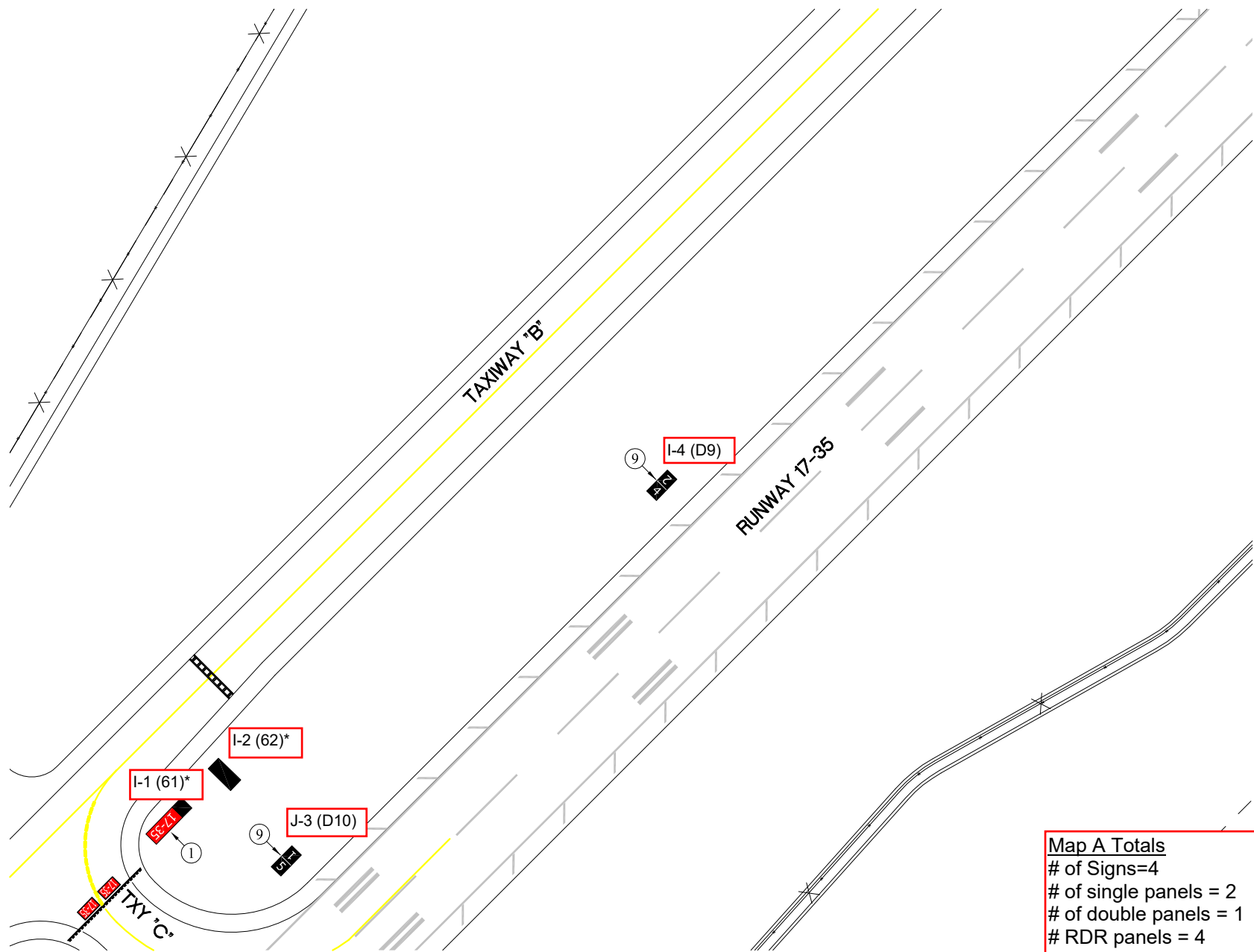

**Map A Totals**  
 # of Signs=4  
 # of single panels = 2  
 # of double panels = 1  
 # RDR panels = 4

Note: RDR sign panels for Rwy 17-35 to be replaced in Year "4")

\*I-1 - plan view may need to be updated as sign believed to have a C identifier sign  
 \*I-2 - directory (and Google Earth) shows this sign...plan should be updated



**ZONE "G" SIGN SYSTEM PLAN**  
 NOTE: SEE PAGE 10 FOR LEGEND

-9-

APPENDIX 4

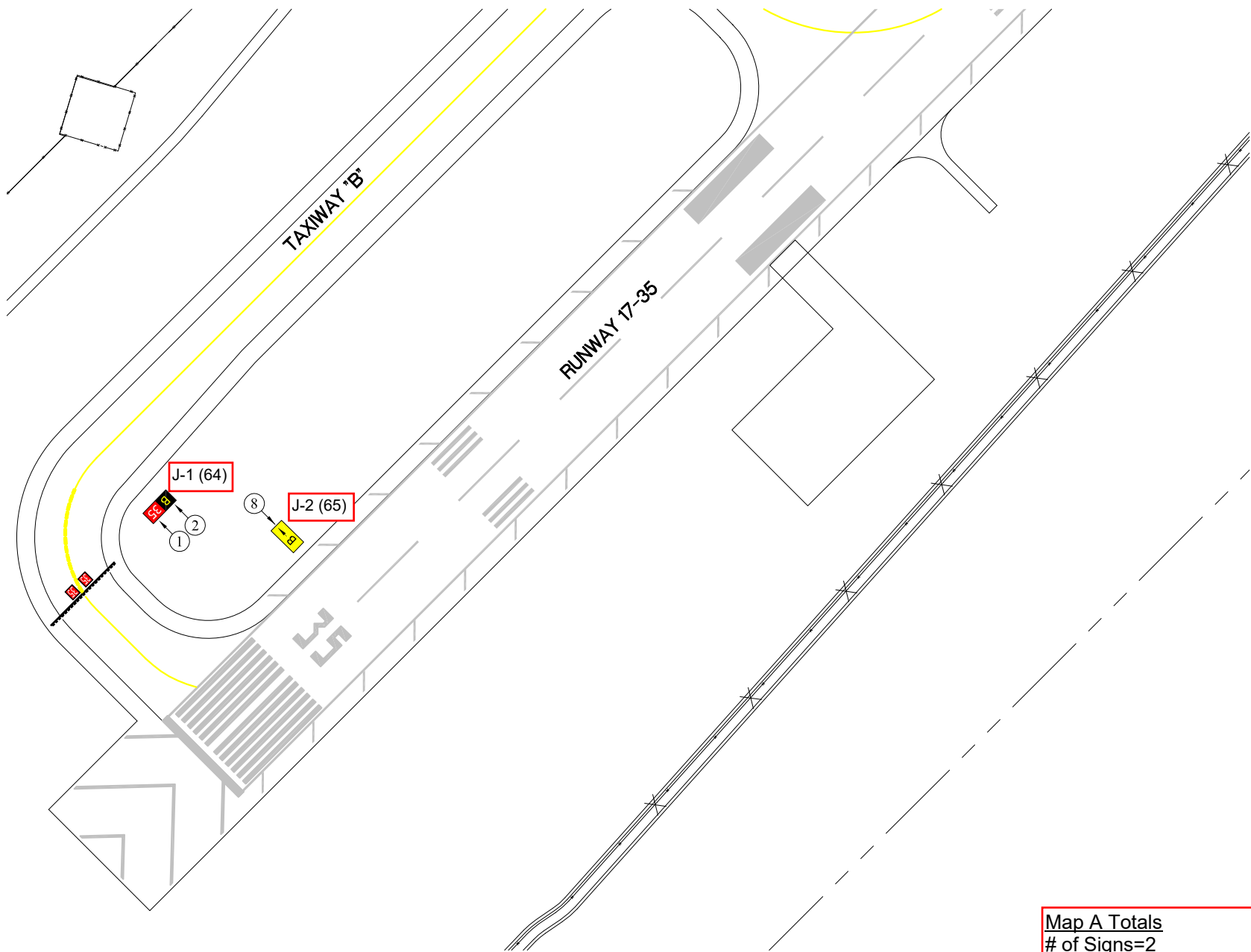

# ZONE "H" SIGN SYSTEM PLAN

NOTE: SEE PAGE 10 FOR LEGEND

**Map A Totals**  
 # of Signs=2  
 # of single panels = 1  
 # of double panels = 1  
 # RDR panels = 4

## LEGEND

- ① "Holding Position Sign for Taxiway/Runway Intersection".  
(AC 150/5340-18C, Paragraph 5.a., Figure 1)
- ② "Taxiway Location Sign" outboard of Holding Position Sign.  
(AC 150/5340-18C, Paragraph 6.a., Figure 11; Paragraph 12.d., Figure 3, Taxiway B)
- ③ "Taxiway Location Sign" on back side of Holding Position Sign.  
(AC 150/5340-18C, Paragraph 12.c. (4))
- ④ "Holding Position Sign for ILS Critical Area".  
(AC 150/5340-18C, Paragraph 5.c. and 12.c. (2))
- ⑤ "ILS Critical Area Boundary Sign" on back side of Holding Position Sign for ILS Critical Area.  
(AC 150/5340-18C, Paragraph 6.d., Figure 14)
- ⑥ "Holding Position Sign for Runway/Runway Intersection".  
(AC 150/5340-18C, Paragraph 5.b.)
- ⑦ "Taxiway Direction Sign".  
(AC 150/5340-18C, Paragraph 7.a.)
- ⑧ "Runway Exit Sign".  
(AC 150/5340-18C, Paragraph 7.b., Figure 15)
- ⑨ "Runway Distance Remaining Signs".  
(AC 150/5340-18C, Chapter 2)
- ⑩ "Inbound Destination Sign".  
(AC 150/5340-18C, Paragraph 9.b., Figure 19)
- ⑪ "Taxiway Ending Marker".  
(AC 150/5340-18F, Paragraph 9, Figure 11)
- ⑫ "Runway Safety Area/OFZ and Runway Approach Boundary Sign"  
on back side of Holding Position Sign.  
(AC 150/5340-18E, Paragraph 7.a., Figure 9.a.)
- ⑬ "Outbound Destination Sign".  
(AC 150/5340-18F, Paragraph 10.a., Figure 11.c.)

STATEWIDE  
AIRFIELD SIGNAGE MAPS AND DATA EXHIBIT MAP "A"

Report as of

| SIGN ID # | SIGN NO. | LEGEND                        | SIZE | # OF MODULES | ADDITIONAL REMARKS |
|-----------|----------|-------------------------------|------|--------------|--------------------|
| A-1       | 1        | M 3 (BLANK)<br>TERM -->       | 3    | 3            |                    |
| A-2       | 2        | M --><br>(BLANK)              | 3    | 1            |                    |
| A-3       | 3        | <-M A<br>(BLANK)              | 3    | 2            |                    |
| A-4       | 4        | <-L<br>(BLANK)                | 3    | 1            |                    |
| A-5       | 6        | <-3<br>(BLANK)                | 3    | 1            |                    |
| A-6       | 7        | <- TERM A<br>(BLANK)          | 3    | 3            |                    |
| A-7       | 8        | K --><br>(BLANK)              | 3    | 1            |                    |
| A-8       | 9        | L 2 1 - 3<br>TERM --> (BLANK) | 3    | 3            |                    |
| A-9       | 10       | L --><br><-K                  | 3    | 1            |                    |
| A-10      | 11       | K --><br>(BLANK)              | 3    | 1            |                    |
| A-11      | 12       | K 2 1 - 3<br>TERM ^ (BLANK)   | 3    | 3            |                    |
| A-12      | 13       | TERM --><br>(BLANK)           | 3    | 3            |                    |
| A-13      | 14       | K <- A --><br>(BLANK)         | 3    | 3            |                    |
| A-14      | 15       | <- K<br>(BLANK)               | 3    | 1            |                    |
| A-15      | 16       | 3 ^ (BLANK)<br>1 7 - 3 5 ^    | 3    | 2            |                    |
| A-16      | 17       | <- TERM<br>(BLANK)            | 3    | 3            |                    |
| A-17      | 18       | J --><br>(BLANK)              | 3    | 1            |                    |
| A-18      | 25       | < - J<br>(BLANK)              | 3    | 1            |                    |
| A-19      | D1       | 5<br>1                        | 4    | 1            |                    |

LIHUE AIRPORT

AIRFIELD SIGNAGE MAPS AND DATA EXHIBIT MAP "B"

Report as of

| SIGN ID # | SIGN NO. | LEGEND                           | SIZE | # OF MODULES | ADDITIONAL REMARKS |
|-----------|----------|----------------------------------|------|--------------|--------------------|
| B-1       | 19       | TERM →<br>(BLANK)                | 3    | 3            |                    |
| B-2       | 20       | J ← A →<br>(BLANK)               | 3    | 3            |                    |
| B-3       | 21       | ← J<br>(BLANK)                   | 3    | 1            |                    |
| B-4       | 22       | A 3 ^ (BLANK)<br>17 - 35 →       | 3    | 3            |                    |
| B-5       | 23       | ← D A D →<br>(BLANK)             | 3    | 3            |                    |
| B-6       | 30       | ← D<br>(BLANK)                   | 3    | 1            |                    |
| B-7       | 29       | ← A ← D D A →<br>CARGO ^ (BLANK) | 3    | 4            |                    |
| B-8       | 28       | 17 - 21 ^<br>A D →               | 3    | 2            |                    |
| B-9       | 33       | ← CARGO<br>CARGO →               | 3    | 3            |                    |
| B-10      | 24       | J 21-3<br>TERM ^ (BLANK)         | 3    | 3            |                    |
| B-11      | 26       | J →<br>(BLANK)                   | 3    | 1            |                    |
| B-12      | 27       | ← CARGO<br>(BLANK)               | 3    | 3            |                    |
| B-13      | 32       | ← A D D → A →<br>(BLANK) (BLANK) | 3    | 4            |                    |
| B-14      | 31       | D 21-3<br>(non-mvmt) D           | 3    | 3            |                    |
| B-15      | D2       | 4<br>2                           | 4    | 1            |                    |
| B-16      | D3       | 3<br>3                           | 4    | 1            |                    |

LIHUE AIRPORT

AIRFIELD SIGNAGE MAPS AND DATA EXHIBIT MAP "C"

Report as of

| SIGN ID# | SIGN NO. | LEGEND                           | SIZE | # OF MODULES | ADDITIONAL REMARKS |
|----------|----------|----------------------------------|------|--------------|--------------------|
| C-1      | 36       | H →<br>(BLANK)                   | 3    | 1            |                    |
| C-2      | 35       | ← H A<br>T E R M ^               | 3    | 2            |                    |
| C-3      | 34       | D →<br>← H                       | 3    | 1            |                    |
| C-4      | 37       | ← A H H → A →<br>(BLANK) (BLANK) | 3    | 4            |                    |
| C-5      | **       | ← G<br>(BLANK)                   | 3    | 1            |                    |
| (added)  |          | ← G A<br>(BLANK)                 | 3    | 2            |                    |
| C-6      | **       | G ← A →<br>(BLANK)               | 3    | 3            |                    |
| C-7      | **       | A G →<br>(BLANK)                 | 3    | 2            |                    |
| C-8      | **       | F →<br>(BLANK)                   | 3    | 1            |                    |
| C-9      | **       | ← F A<br>(BLANK)                 | 3    | 2            |                    |
| C-10     | **       | ← F<br>(BLANK)                   | 3    | 1            |                    |
| C-11     | **       | F ← A →<br>(BLANK)               | 3    | 3            |                    |
| C-12     | **       | A F →<br>(BLANK)                 | 3    | 2            |                    |
| C-13     | 39       | H 2 1 - 3<br>← C A R G O         | 3    | 3            |                    |
| C-14     | 44       | C A R G O →<br>(BLANK)           | 3    | 3            |                    |
| C-15     | D4       | 2<br>4                           | 4    | 1            |                    |

LIHUE AIRPORT

AIRFIELD SIGNAGE MAPS AND DATA EXHIBIT MAP "D"

Report as of

| SIGN ID # | SIGN NO. | LEGEND                             | SIZE | # OF MODULES | ADDITIONAL REMARKS |
|-----------|----------|------------------------------------|------|--------------|--------------------|
| D-1       | **       | B --><br>(BLANK)                   | 3    | 1            |                    |
| D-2       | **       | <- B A<br>(BLANK)                  | 3    | 2            |                    |
| D-3       | **       | <- B<br>(BLANK)                    | 3    | 1            |                    |
| D-4       | **       | B <- A --><br>(BLANK)              | 3    | 3            |                    |
| D-5       | **       | A B --><br>(BLANK)                 | 3    | 2            |                    |
| (added)   | 46       | A B --><br>(BLANK)                 | 3    | 2            |                    |
| (added)   | 47       | 17 --><br>TERM ^                   | 3    | 2            |                    |
| D-6       | 48       | 17 - A P C H<br>(non-mvmt) (BLANK) | 3    | 3            |                    |
| D-7       | 49       | 21 --><br>TERM ^                   | 3    | 2            |                    |
| D-8       | 50       | A 21 (BLANK)<br><- TERM            | 3    | 3            |                    |
| D-9       | 51       | <- A<br>(BLANK)                    | 3    | 1            |                    |
| D-10      | 52       | B 21 - 3<br>(non-mvmt) B           | 3    | 3            |                    |
| D-11      | 77       | B <- A --><br>(BLANK)              | 3    | 3            |                    |
| D-12      | 53       | <- B<br>(BLANK)                    | 3    | 1            |                    |
| D-13      | D5       | 1<br>5                             | 4    | 1            |                    |

LIHUE AIRPORT

AIRFIELD SIGNAGE MAPS AND DATA EXHIBIT MAP "E"

Report as of

| SIGN ID #  | SIGN NO. | LEGEND  | SIZE    | # OF MODULES | ADDITIONAL REMARKS |            |  |   |   |   |  |
|------------|----------|---|---------|--------------|--------------------|------------|--|---|---|---|--|
| E-1        | 41       | <table border="1"> <tr> <td>TERM ^</td> <td></td> <td></td> </tr> <tr> <td>(BLANK)</td> <td></td> <td></td> </tr> </table>      | TERM ^  |              |                    | (BLANK)    |  |   | 3 | 2 |  |
| TERM ^     |          |   |         |              |                    |            |  |   |   |   |  |
| (BLANK)    |          |   |         |              |                    |            |  |   |   |   |  |
| E-2        | 40       | <table border="1"> <tr> <td>D</td> <td>3-21</td> <td></td> </tr> <tr> <td>(non-mvmt)</td> <td></td> <td>D</td> </tr> </table>   | D       | 3-21         |                    | (non-mvmt) |  | D | 3 | 3 |  |
| D          | 3-21     |   |         |              |                    |            |  |   |   |   |  |
| (non-mvmt) |          | D   |         |              |                    |            |  |   |   |   |  |
| E-3        | 42       | <table border="1"> <tr> <td>^ 17-35</td> <td></td> <td></td> </tr> <tr> <td>CARGO ^</td> <td></td> <td></td> </tr> </table>     | ^ 17-35 |              |                    | CARGO ^    |  |   | 3 | 3 |  |
| ^ 17-35    |          |   |         |              |                    |            |  |   |   |   |  |
| CARGO ^    |          |   |         |              |                    |            |  |   |   |   |  |
| E-4        | 43       | <table border="1"> <tr> <td>D ^</td> <td>D</td> <td>H--&gt;</td> </tr> <tr> <td>(BLANK)</td> <td></td> <td></td> </tr> </table> | D ^     | D            | H-->               | (BLANK)    |  |   | 3 | 3 |  |
| D ^        | D        | H-->  |         |              |                    |            |  |   |   |   |  |
| (BLANK)    |          |   |         |              |                    |            |  |   |   |   |  |

LIHUE AIRPORT

AIRFIELD SIGNAGE MAPS AND DATA EXHIBIT MAP "F"

Report as of

| SIGN ID # | SIGN NO. | LEGEND                              | SIZE | # OF MODULES | ADDITIONAL REMARKS |
|-----------|----------|-------------------------------------|------|--------------|--------------------|
| F-1       | 54       | B 3-21<br>(non-mvmt) B              | 3    | 3            |                    |
| F-2       | 55       | <- E B (BLANK)<br>^ RAMP            | 3    | 3            |                    |
| F-3       | 75       | <- 17<br>(BLANK)                    | 3    | 2            |                    |
| F-4       | 56       | E 17 (BLANK)<br>E <- B ->           | 3    | 3            |                    |
| F-5       | 74       | 35 ^ (BLANK)<br>^ RAMP              | 3    | 3            |                    |
| F-6       | 76       | 17 -><br>(BLANK)                    | 3    | 2            |                    |
| F-7       | 57       | <- E<br>(BLANK)                     | 3    | 1            |                    |
| F-8       | 68       | <- B D D -> B -><br>(BLANK) (BLANK) | 3    | 4            |                    |
| F-9       | 71       | 35 -> (BLANK)<br>^ RAMP             | 3    | 3            |                    |
| F-10      | 72       | <- 17<br>(BLANK)                    | 3    | 2            |                    |
| F-11      | 73A      | B D -><br>MONITOR TOWER ON 118.9    | 3    | 3            |                    |

LIHUE AIRPORT

AIRFIELD SIGNAGE MAPS AND DATA EXHIBIT MAP "G"

Report as of

| SIGN ID # | SIGN NO. | LEGEND       | SIZE | # OF MODULES | ADDITIONAL REMARKS |
|-----------|----------|--------------|------|--------------|--------------------|
| G-1       | 70       | 3 5 ^        | 3    | 2            |                    |
|           |          | <- D B       |      |              |                    |
| G-2       | 58       | D 17 - 3 5   | 3    | 3            |                    |
|           |          | <- D D B --> |      |              |                    |
| G-3       | 59       | <- R A M P   | 3    | 3            |                    |
|           |          | (BLANK)      |      |              |                    |
| G-4       | 60       | <- D         | 3    | 1            |                    |
|           |          | (BLANK)      |      |              |                    |
| G-5       | D6       | 5            | 4    | 1            |                    |
|           |          | 1            |      |              |                    |

LIHUE AIRPORT

AIRFIELD SIGNAGE MAPS AND DATA EXHIBIT MAP "H"

Report as of

| SIGN ID # | SIGN NO. | LEGEND |  |  | SIZE | # OF MODULES | ADDITIONAL REMARKS |
|-----------|----------|--------|--|--|------|--------------|--------------------|
| H-1       | D7       | 4      |  |  | 4    | 1            |                    |
|           |          | 2      |  |  |      |              |                    |
| H-2       | D8       | 3      |  |  | 4    | 1            |                    |
|           |          | 3      |  |  |      |              |                    |

LIHUE AIRPORT

AIRFIELD SIGNAGE MAPS AND DATA EXHIBIT MAP "I"

Report as of

| SIGN ID # | SIGN NO. | LEGEND                                 | SIZE | # OF MODULES | ADDITIONAL REMARKS |
|-----------|----------|--|------|--------------|--------------------|
| I-1       | 61       | <b>C</b><br><b>17 - 3 5</b><br>(BLANK) | 3    | 3            |                    |
| I-2       | 62       | <b>&lt;- C</b><br>(BLANK)              | 3    | 1            |                    |
| I-3       | 63       | <b>C --&gt;</b><br>(BLANK)             | 3    | 1            |                    |
| I-4       | D9       | <b>2</b><br><b>4</b>                   | 4    | 1            |                    |

LIHUE AIRPORT

AIRFIELD SIGNAGE MAPS AND DATA EXHIBIT MAP "J"

Report as of

| SIGN ID #          | SIGN NO.   | LEGEND  | SIZE            | # OF MODULES | ADDITIONAL REMARKS |  |                    |  |  |  |   |   |  |
|--------------------|------------|---|-----------------|--------------|--------------------|--|--------------------|--|--|--|---|---|--|
| J-1                | 64         | <table border="1"> <tr> <td><b>B</b></td> <td><b>3 5</b></td> <td></td> <td></td> </tr> <tr> <td colspan="4"><i>TERM --&gt;</i></td> </tr> </table> | <b>B</b>        | <b>3 5</b>   |                    |  | <i>TERM --&gt;</i> |  |  |  | 3 | 2 |  |
| <b>B</b>           | <b>3 5</b> |   |                 |              |                    |  |                    |  |  |  |   |   |  |
| <i>TERM --&gt;</i> |            |   |                 |              |                    |  |                    |  |  |  |   |   |  |
| J-2                | 65         | <table border="1"> <tr> <td><b>B --&gt;</b></td> <td></td> <td></td> <td></td> </tr> <tr> <td colspan="4"><i>(BLANK)</i></td> </tr> </table>        | <b>B --&gt;</b> |              |                    |  | <i>(BLANK)</i>     |  |  |  | 3 | 1 |  |
| <b>B --&gt;</b>    |            |   |                 |              |                    |  |                    |  |  |  |   |   |  |
| <i>(BLANK)</i>     |            |   |                 |              |                    |  |                    |  |  |  |   |   |  |
| J-3                | D10        | <table border="1"> <tr> <td>1</td> <td></td> <td></td> <td></td> </tr> <tr> <td>5</td> <td></td> <td></td> <td></td> </tr> </table>                 | 1               |              |                    |  | 5                  |  |  |  | 4 | 1 |  |
| 1                  |            |   |                 |              |                    |  |                    |  |  |  |   |   |  |
| 5                  |            |   |                 |              |                    |  |                    |  |  |  |   |   |  |

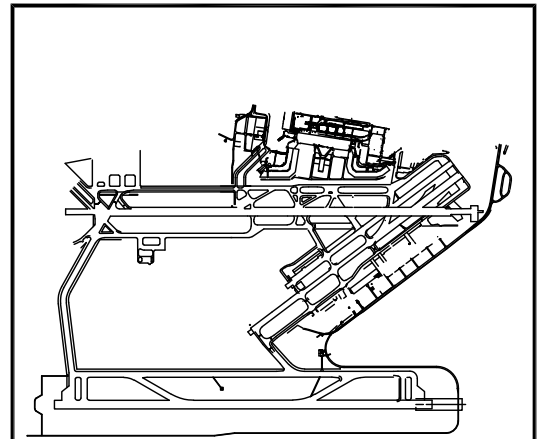
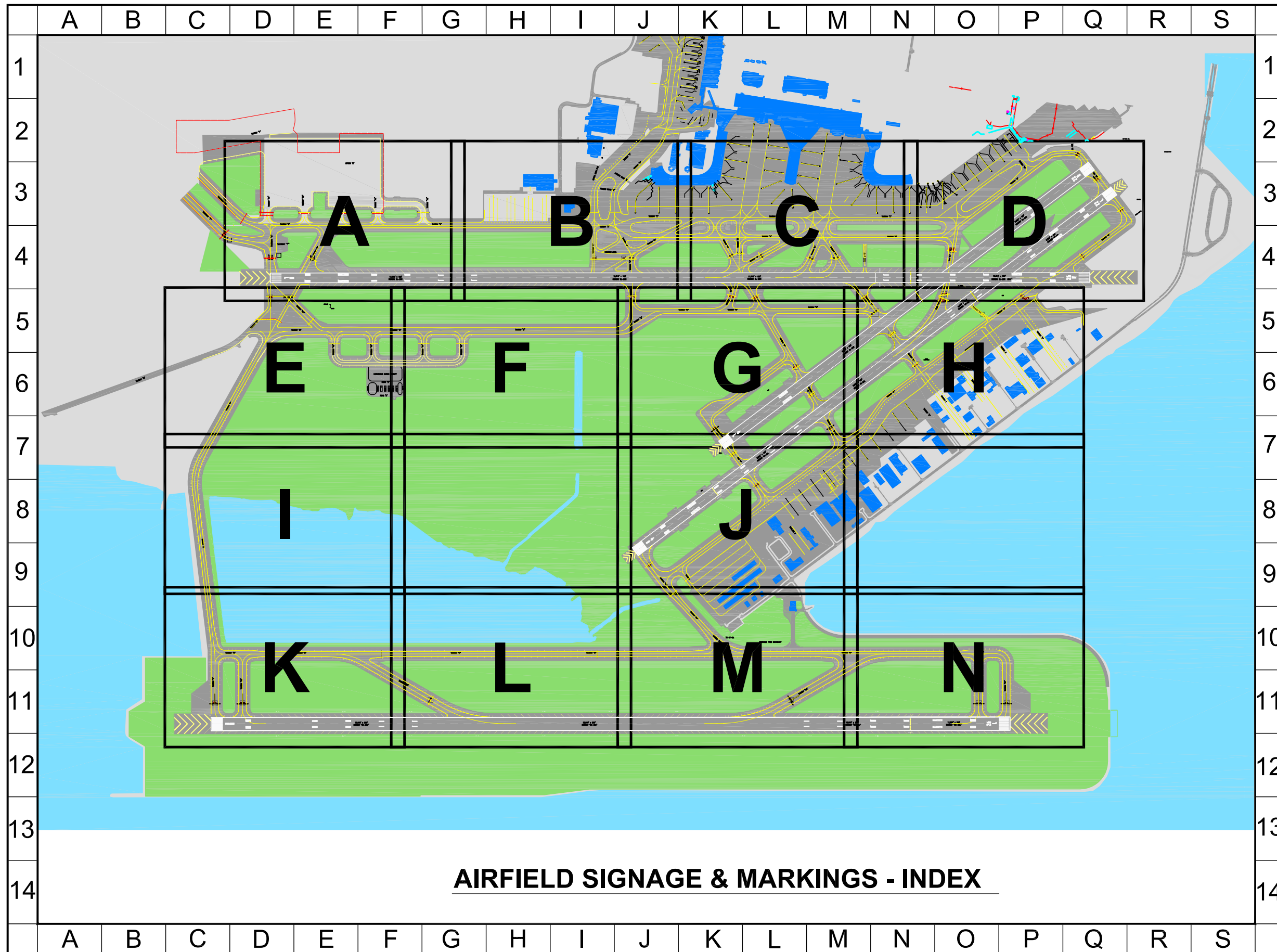

|                                       |                   |
|---------------------------------------|-------------------|
| DANIEL K. INOUE INTERNATIONAL AIRPORT |                   |
| AIRFIELD SIGNAGE & MARKINGS           | EXHIBIT:<br>INDEX |

Original Date: \_\_\_\_\_ Revision Date: \_\_\_\_\_ FAA Approval: \_\_\_\_\_

|    |  |   |   |   |   |   |   |   |   |   |   |   |   |   |   |   |   |   |   |  |
|----|--|---|---|---|---|---|---|---|---|---|---|---|---|---|---|---|---|---|---|--|
|    | A  | B | C | D | E | F | G | H | I | J | K | L | M | N | O | P | Q | R | S |  |
| 1  | <div style="border: 1px solid black; padding: 10px; margin-bottom: 20px;"> <p><b>SIGN PLAN LEGEND</b></p> <p>■ NEW SIGN / EXISTING AIRPORT SIGNS</p> <p>240 SIGN REFERENCE NUMBER (NON-ILLUMINATED)</p> <p>102 SIGN REFERENCE NUMBER (ILLUMINATED)</p> <p>↓ ↓ ↓ ↓ SIGN LEGENDS</p> <p>↓ ↓ ↓ ↓ SIGN LOCATION AND ORIENTATION</p> <p>3 W/B - WHITE INSCRIPTION / BLACK BACKGROUND - R/W DISTANCE REMAINING</p> <p>11-29 W/R - WHITE INSCRIPTION / RED BACKGROUND - MANDATORY</p> <p>C Y/B - YELLOW INSCRIPTION / BLACK BACKGROUND - LOCATION</p> <p>A ↓ B/Y - BLACK INSCRIPTION / YELLOW BACKGROUND - DIRECTIONAL/DESTINATION/EXIT</p> <p>H HELIPAD</p> <p>T TIE-DOWN</p> <p>TOFA TAXIWAY OBJECT FREE AREA</p> <p>RSA RUNWAY SAFETY AREA</p> <p>LCA LOCALIZER CRITICAL AREA</p> <p>GSCA GLIDE SLOPE CRITICAL AREA</p> </div> <div style="text-align: center; font-weight: bold; font-size: 1.2em;"> <u>AIRFIELD SIGNAGE &amp; MARKINGS - LEGEND</u> </div> |   |   |   |   |   |   |   |   |   |   |   |   |   |   |   |   |   |   |  |
| 2  |  |   |   |   |   |   |   |   |   |   |   |   |   |   |   |   |   |   |   |  |
| 3  |  |   |   |   |   |   |   |   |   |   |   |   |   |   |   |   |   |   |   |  |
| 4  |  |   |   |   |   |   |   |   |   |   |   |   |   |   |   |   |   |   |   |  |
| 5  |  |   |   |   |   |   |   |   |   |   |   |   |   |   |   |   |   |   |   |  |
| 6  |  |   |   |   |   |   |   |   |   |   |   |   |   |   |   |   |   |   |   |  |
| 7  |  |   |   |   |   |   |   |   |   |   |   |   |   |   |   |   |   |   |   |  |
| 8  |  |   |   |   |   |   |   |   |   |   |   |   |   |   |   |   |   |   |   |  |
| 9  |  |   |   |   |   |   |   |   |   |   |   |   |   |   |   |   |   |   |   |  |
| 10 |  |   |   |   |   |   |   |   |   |   |   |   |   |   |   |   |   |   |   |  |
| 11 |  |   |   |   |   |   |   |   |   |   |   |   |   |   |   |   |   |   |   |  |
| 12 |  |   |   |   |   |   |   |   |   |   |   |   |   |   |   |   |   |   |   |  |
| 13 |  |   |   |   |   |   |   |   |   |   |   |   |   |   |   |   |   |   |   |  |
| 14 |  |   |   |   |   |   |   |   |   |   |   |   |   |   |   |   |   |   |   |  |
| A  | B  | C | D | E | F | G | H | I | J | K | L | M | N | O | P | Q | R | S |   |  |

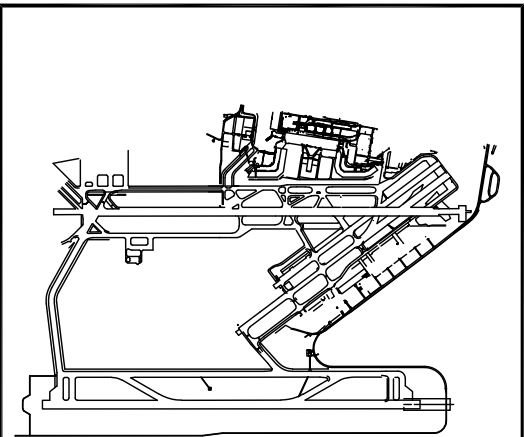

DANIEL K. INOUE INTERNATIONAL AIRPORT

|                             |                    |
|-----------------------------|--------------------|
| AIRFIELD SIGNAGE & MARKINGS | EXHIBIT:<br>LEGEND |
|-----------------------------|--------------------|

Original Date: \_\_\_\_\_ Revision Date: \_\_\_\_\_ FAA Approval: \_\_\_\_\_

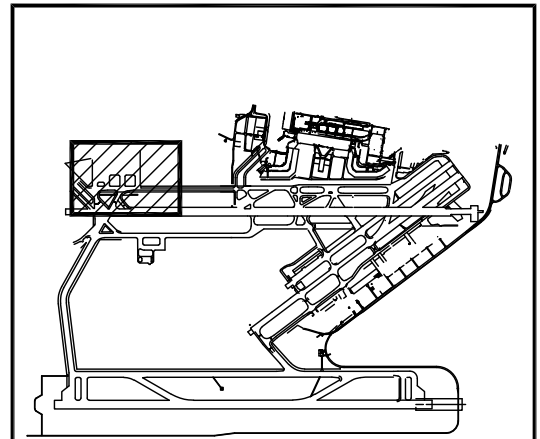
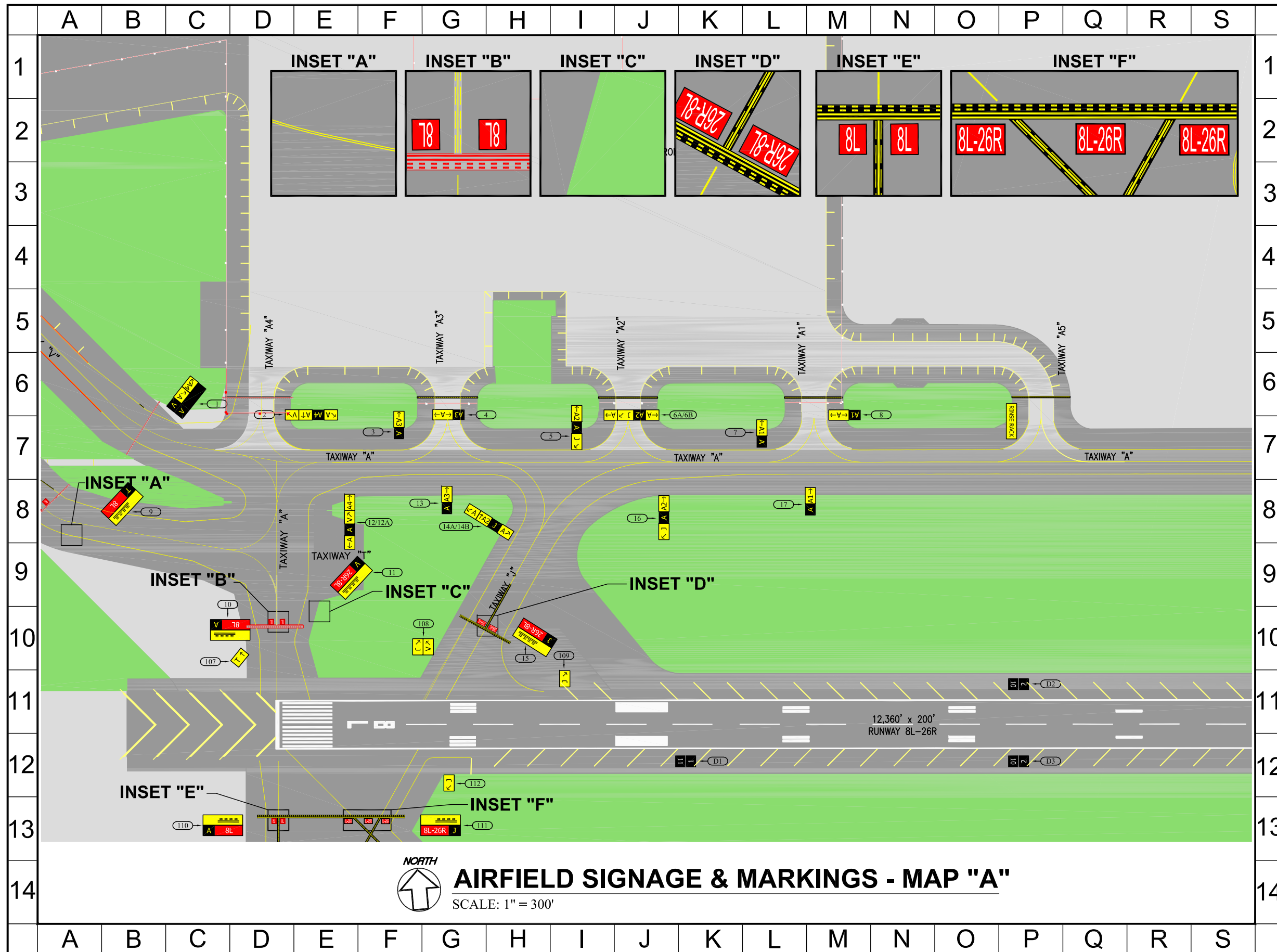

DANIEL K. INOUE INTERNATIONAL AIRPORT

|                             |                  |
|-----------------------------|------------------|
| AIRFIELD SIGNAGE & MARKINGS | EXHIBIT: "MAP A" |
|-----------------------------|------------------|

Original Date: \_\_\_\_\_ Revision Date: \_\_\_\_\_ FAA Approval: \_\_\_\_\_

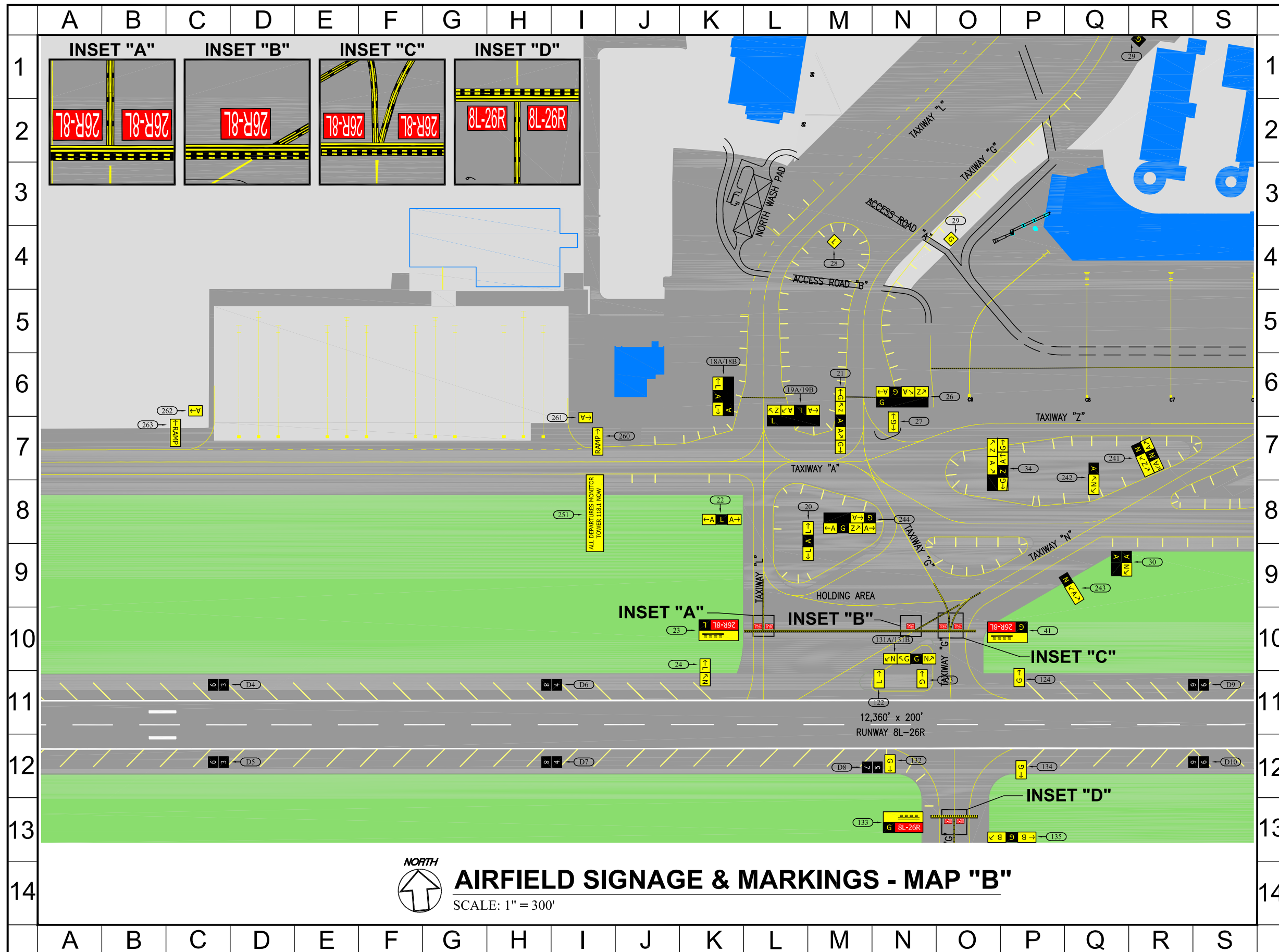

**AIRFIELD SIGNAGE & MARKINGS - MAP "B"**

SCALE: 1" = 300'

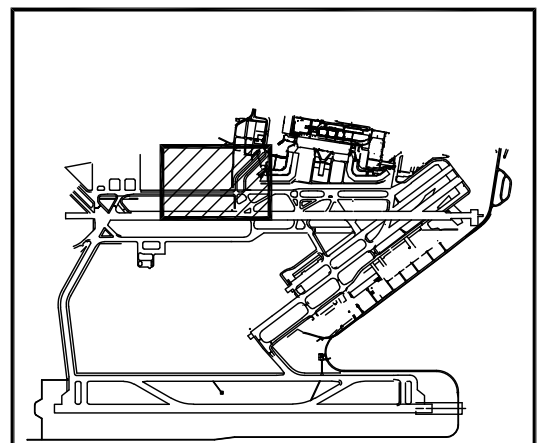

DANIEL K. INOUE INTERNATIONAL AIRPORT

|                             |                     |
|-----------------------------|---------------------|
| AIRFIELD SIGNAGE & MARKINGS | EXHIBIT:<br>"MAP B" |
|-----------------------------|---------------------|

Original Date: \_\_\_\_\_ Revision Date: \_\_\_\_\_ FAA Approval: \_\_\_\_\_

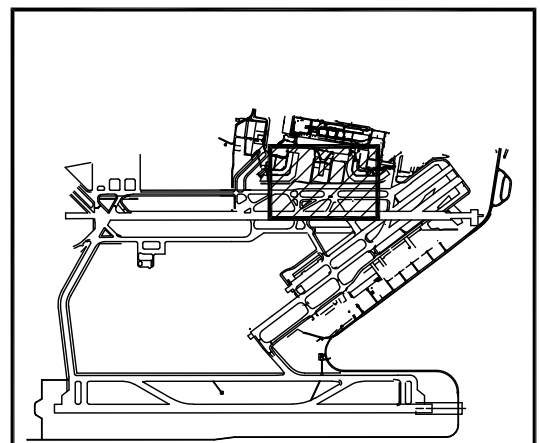
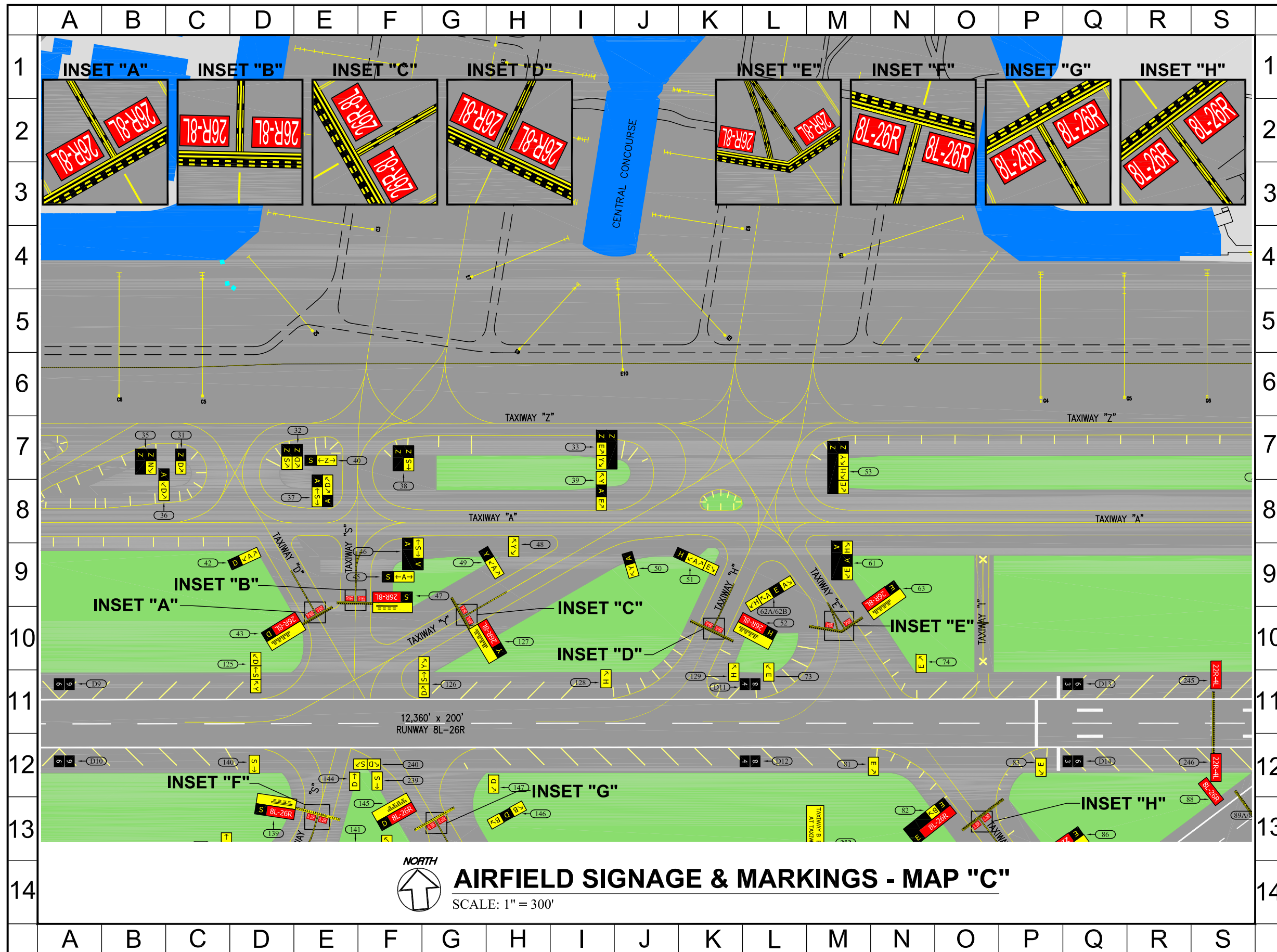

DANIEL K. INOUE INTERNATIONAL AIRPORT

|                             |                     |
|-----------------------------|---------------------|
| AIRFIELD SIGNAGE & MARKINGS | EXHIBIT:<br>"MAP C" |
|-----------------------------|---------------------|

Original Date: \_\_\_\_\_ Revision Date: \_\_\_\_\_ FAA Approval: \_\_\_\_\_

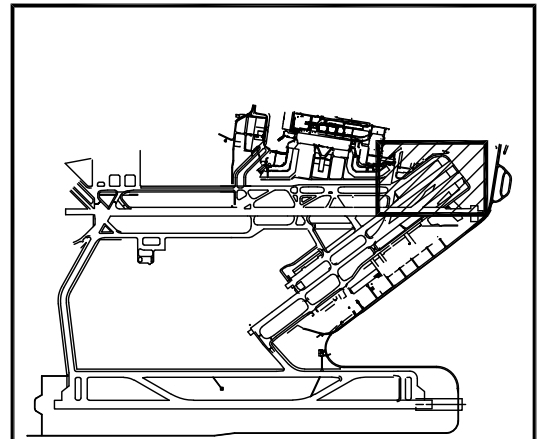
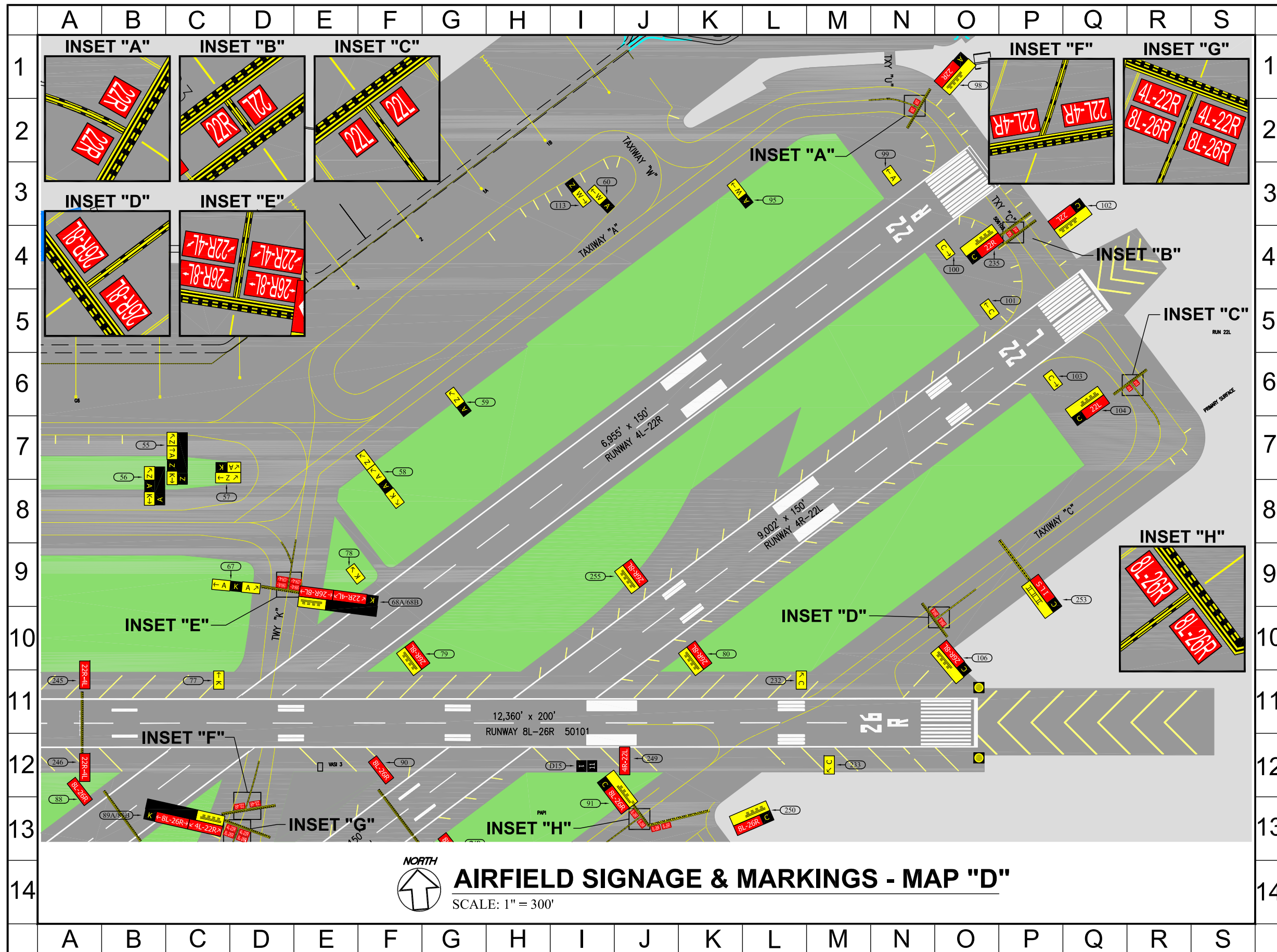

DANIEL K. INOUE INTERNATIONAL AIRPORT  
 AIRFIELD SIGNAGE & MARKINGS EXHIBIT: "MAP D"

Original Date: \_\_\_\_\_ Revision Date: \_\_\_\_\_ FAA Approval: \_\_\_\_\_

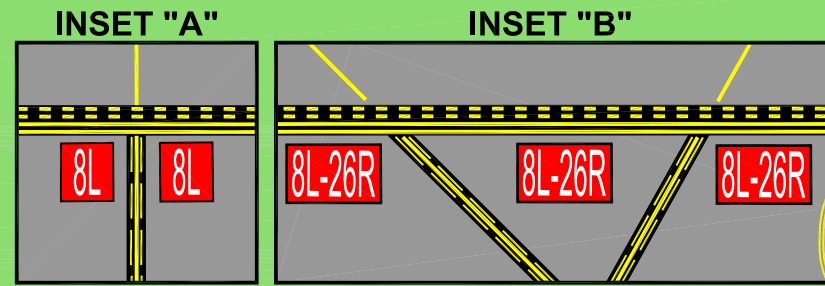
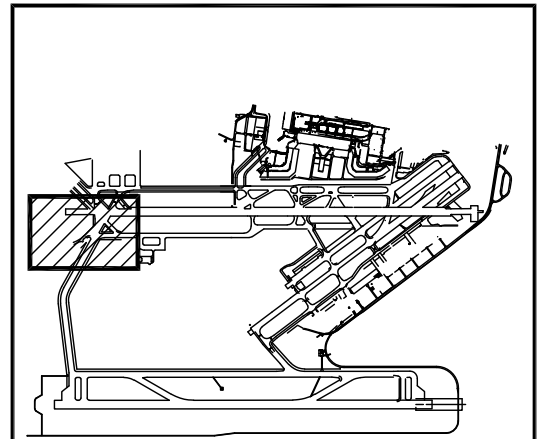
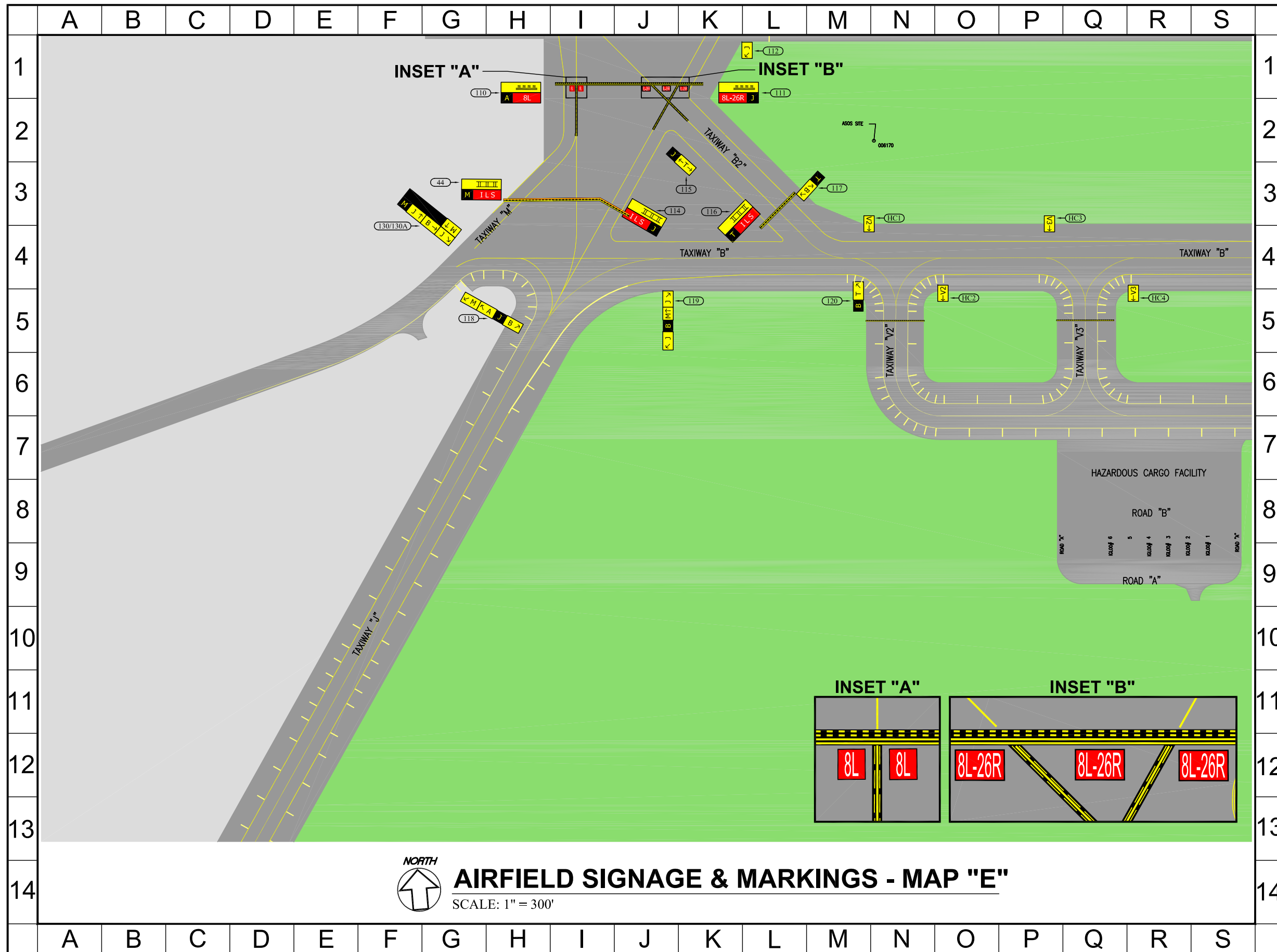

DANIEL K. INOUE INTERNATIONAL AIRPORT  
 AIRFIELD SIGNAGE & MARKINGS EXHIBIT: "MAP E"

Original Date: \_\_\_\_\_ Revision Date: \_\_\_\_\_ FAA Approval: \_\_\_\_\_

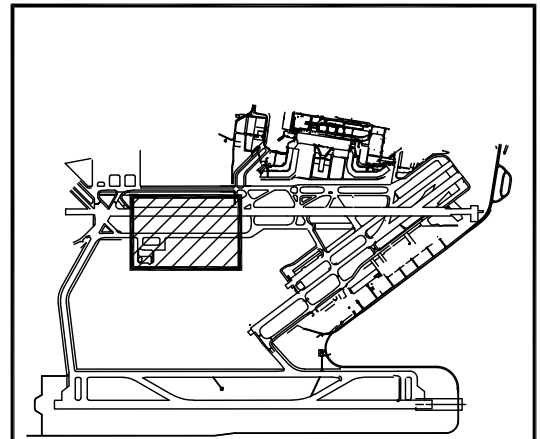
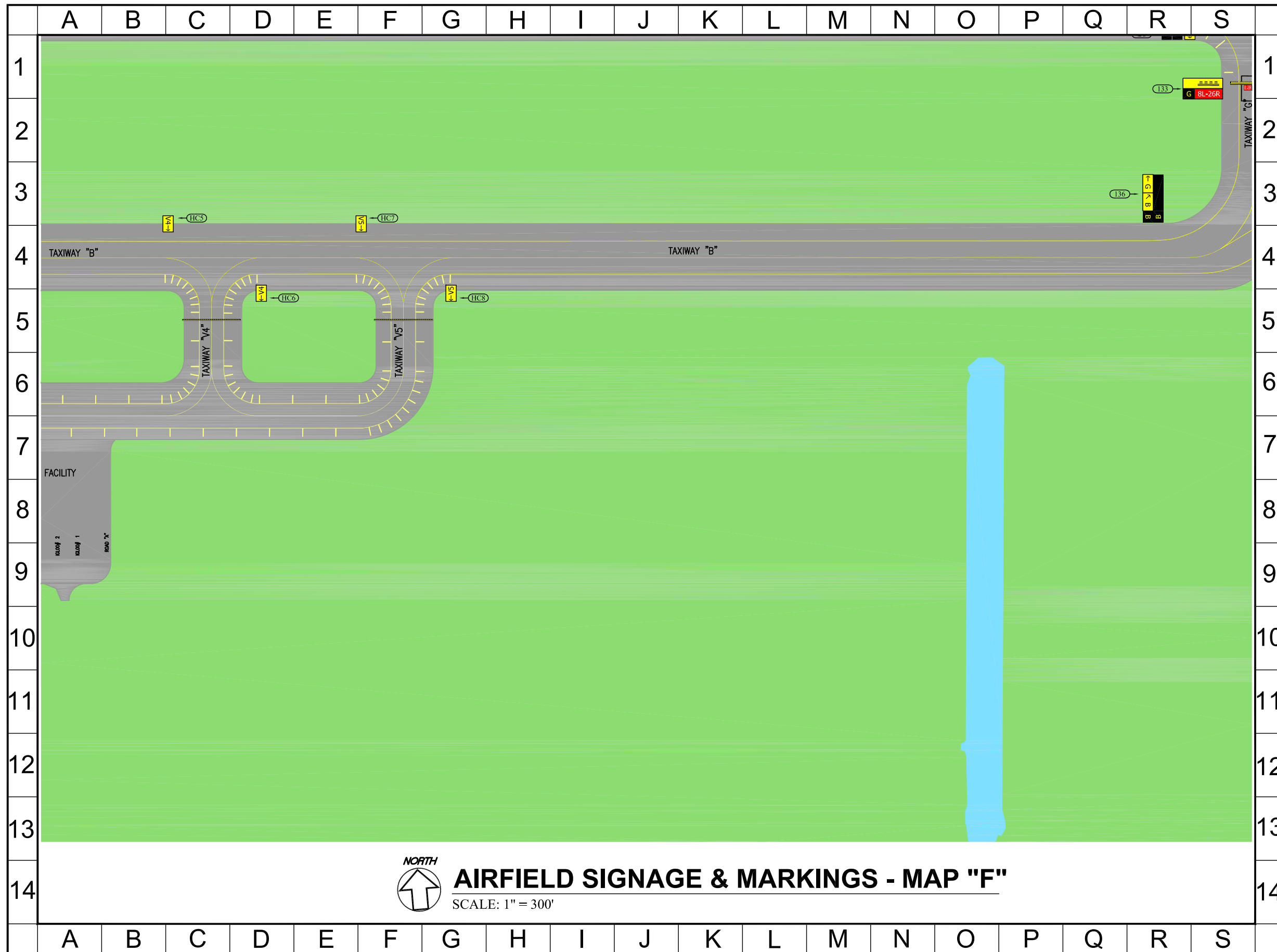

|                                       |                  |
|---------------------------------------|------------------|
| DANIEL K. INOUE INTERNATIONAL AIRPORT |                  |
| AIRFIELD SIGNAGE & MARKINGS           | EXHIBIT: "MAP F" |

Original Date: \_\_\_\_\_ Revision Date: \_\_\_\_\_ FAA Approval: \_\_\_\_\_

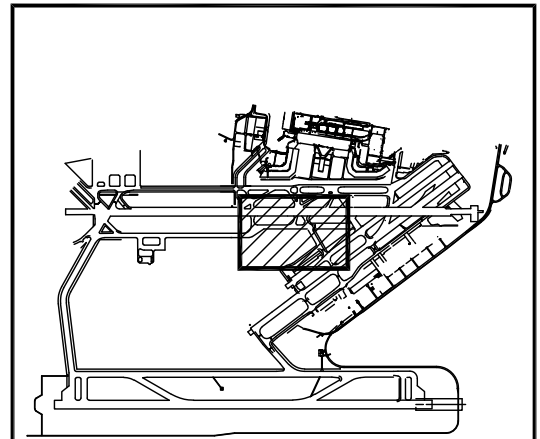
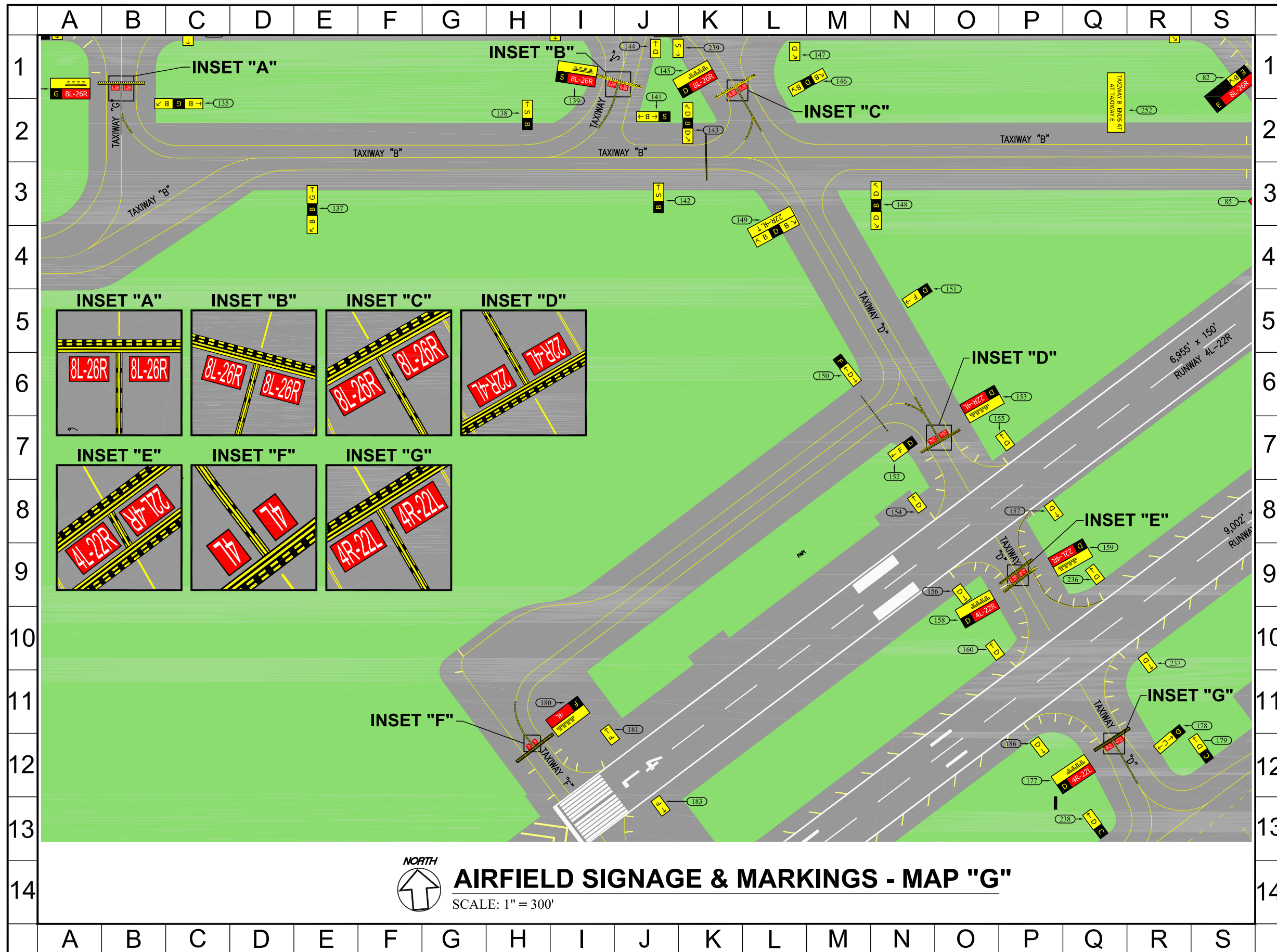

DANIEL K. INOUE INTERNATIONAL AIRPORT  
 AIRFIELD SIGNAGE & MARKINGS EXHIBIT: "MAP G"

Original Date: \_\_\_\_\_ Revision Date: \_\_\_\_\_ FAA Approval: \_\_\_\_\_

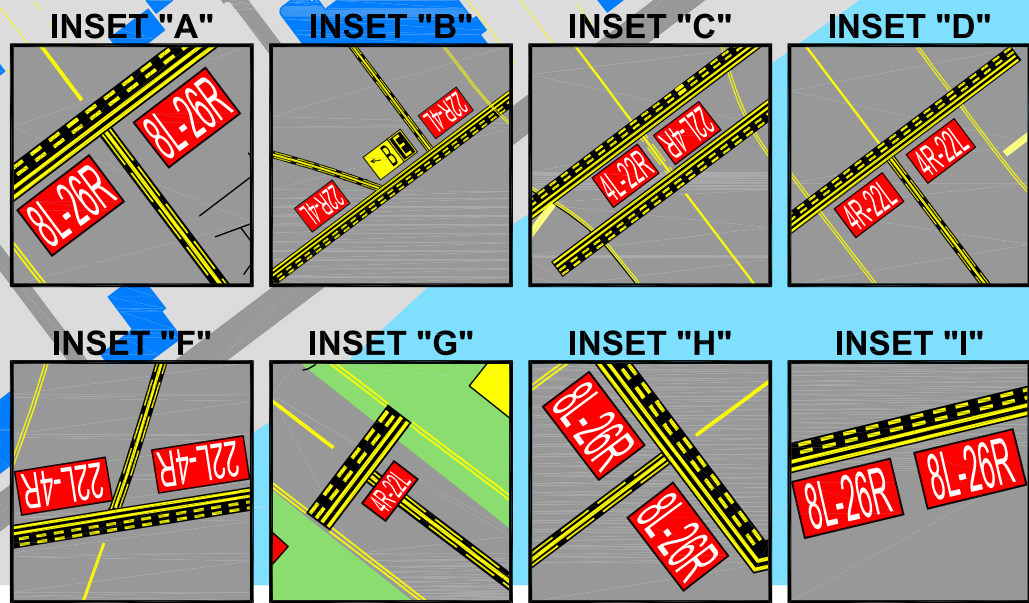
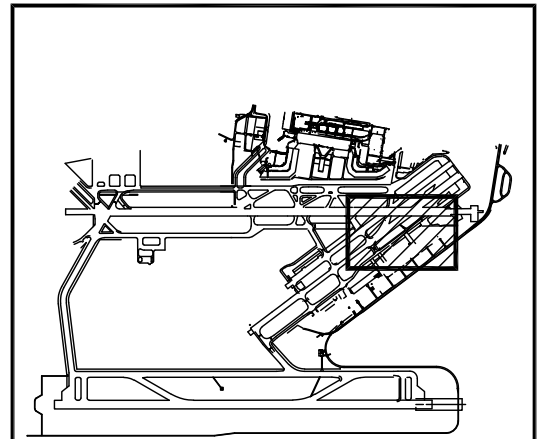
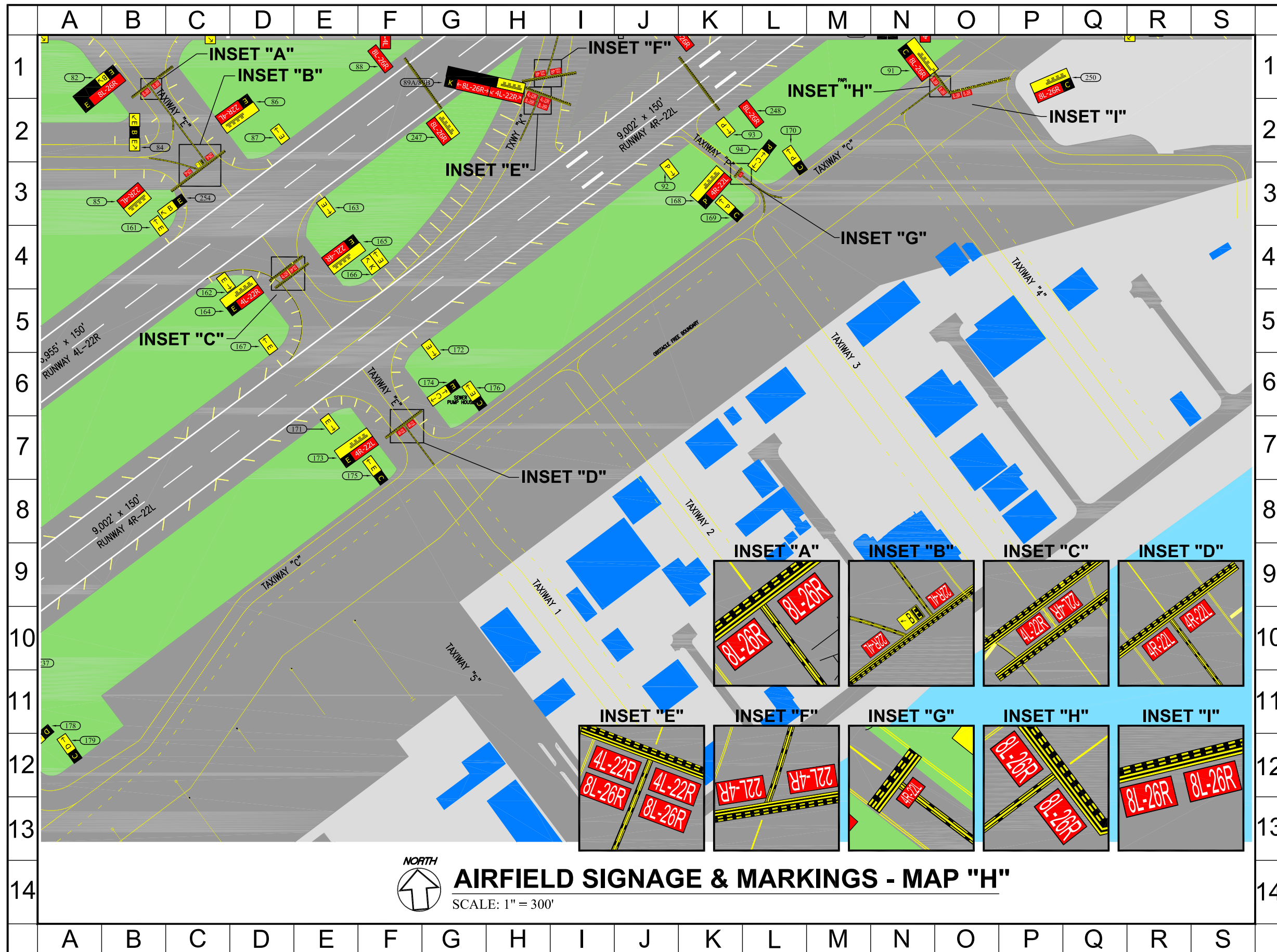

DANIEL K. INOUE INTERNATIONAL AIRPORT  
 AIRFIELD SIGNAGE & MARKINGS EXHIBIT: "MAP H"

Original Date: \_\_\_\_\_ Revision Date: \_\_\_\_\_ FAA Approval: \_\_\_\_\_

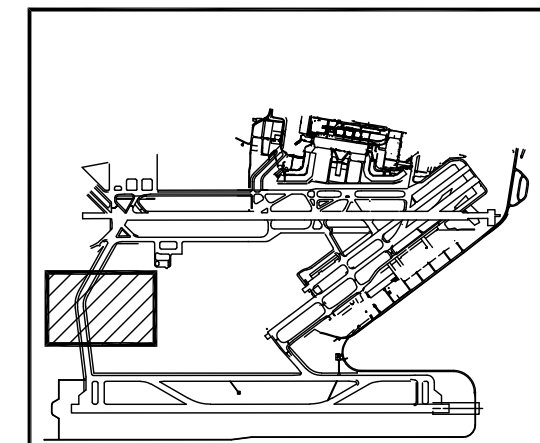
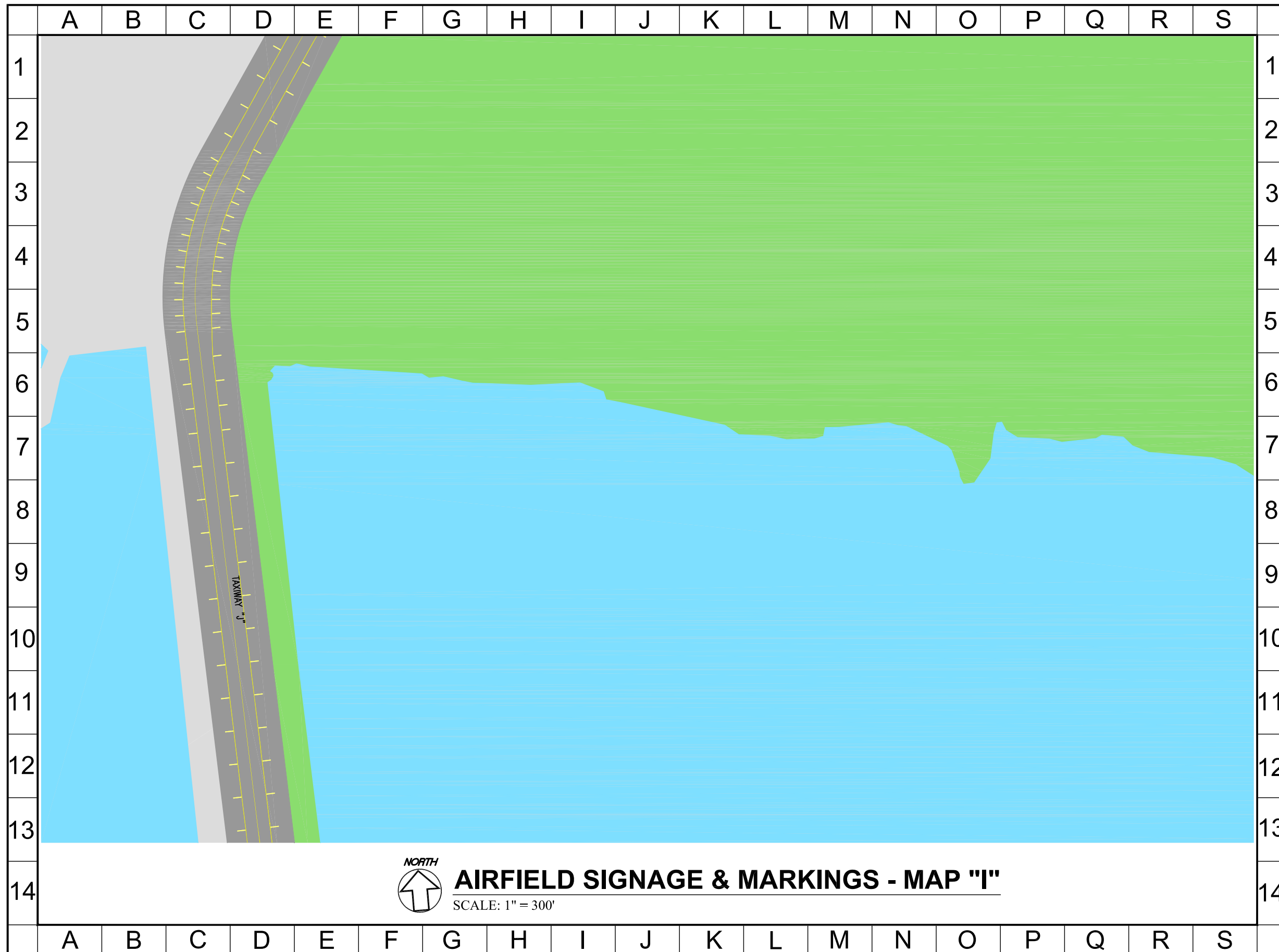

|                                       |                     |
|---------------------------------------|---------------------|
| DANIEL K. INOUE INTERNATIONAL AIRPORT |                     |
| AIRFIELD SIGNAGE & MARKINGS           | EXHIBIT:<br>"MAP I" |

Original Date: \_\_\_\_\_ Revision Date: \_\_\_\_\_ FAA Approval: \_\_\_\_\_

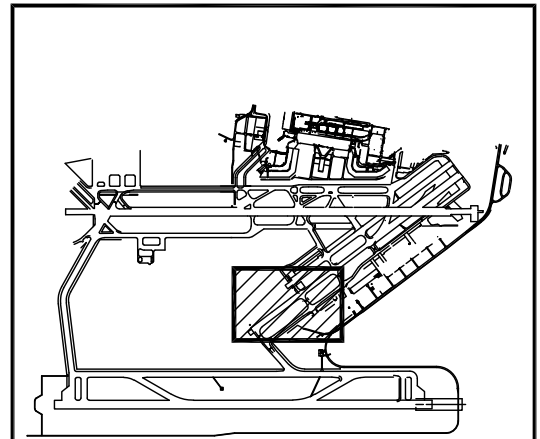
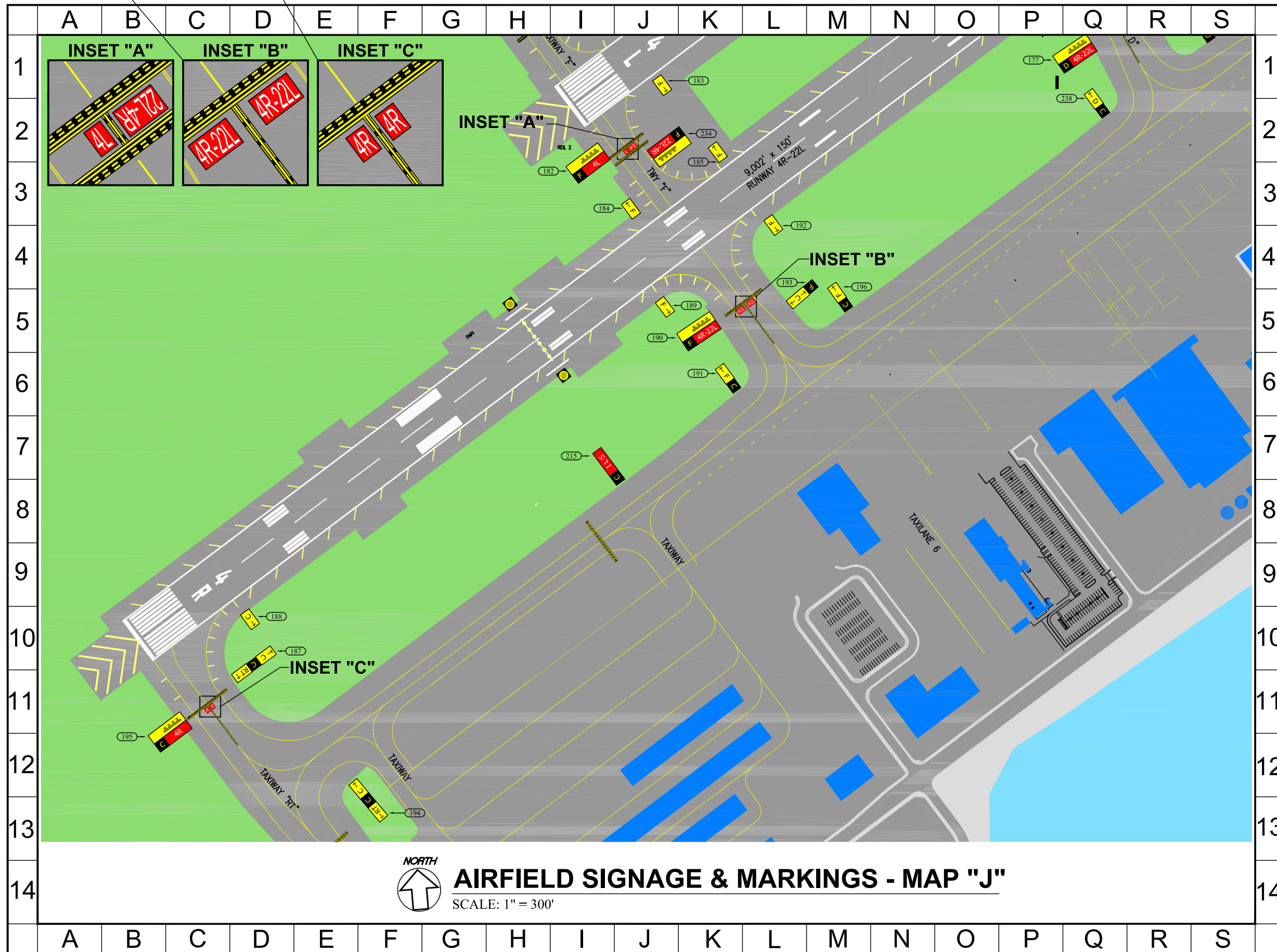

DANIEL K. INOUE INTERNATIONAL AIRPORT  
 AIRFIELD SIGNAGE & MARKINGS EXHIBIT: "MAP J"

Original Date: \_\_\_\_\_ Revision Date: \_\_\_\_\_ FAA Approval: \_\_\_\_\_

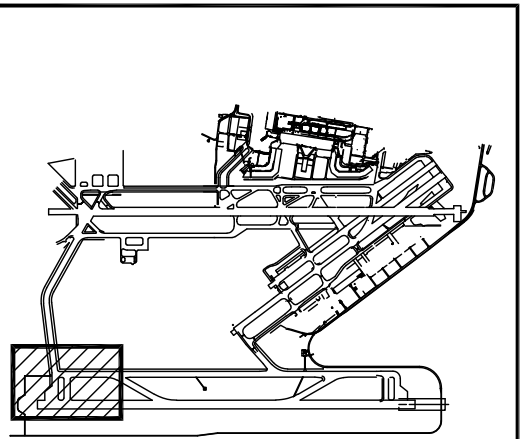
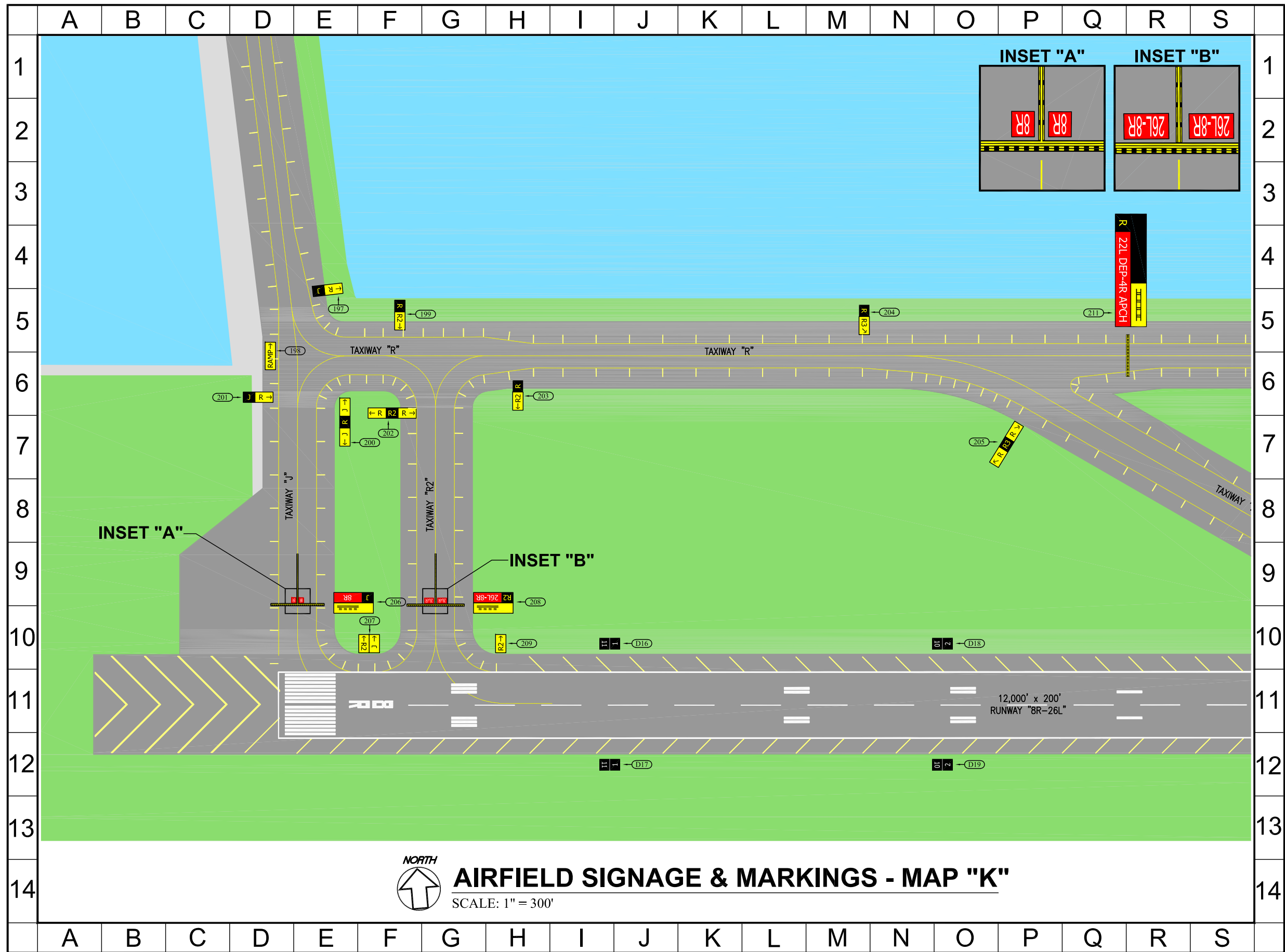

|                                       |                     |
|---------------------------------------|---------------------|
| DANIEL K. INOUE INTERNATIONAL AIRPORT |                     |
| AIRFIELD SIGNAGE & MARKINGS           | EXHIBIT:<br>"MAP K" |

Original Date: \_\_\_\_\_ Revision Date: \_\_\_\_\_ FAA Approval: \_\_\_\_\_

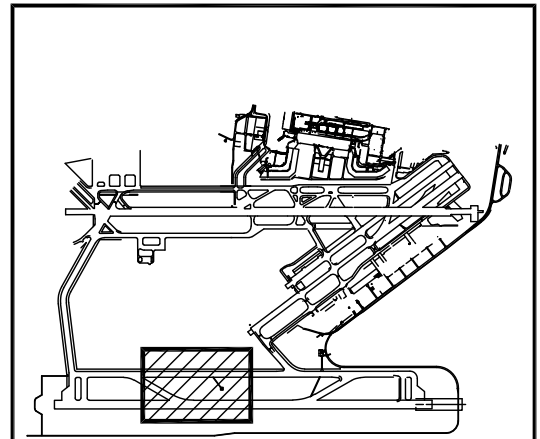
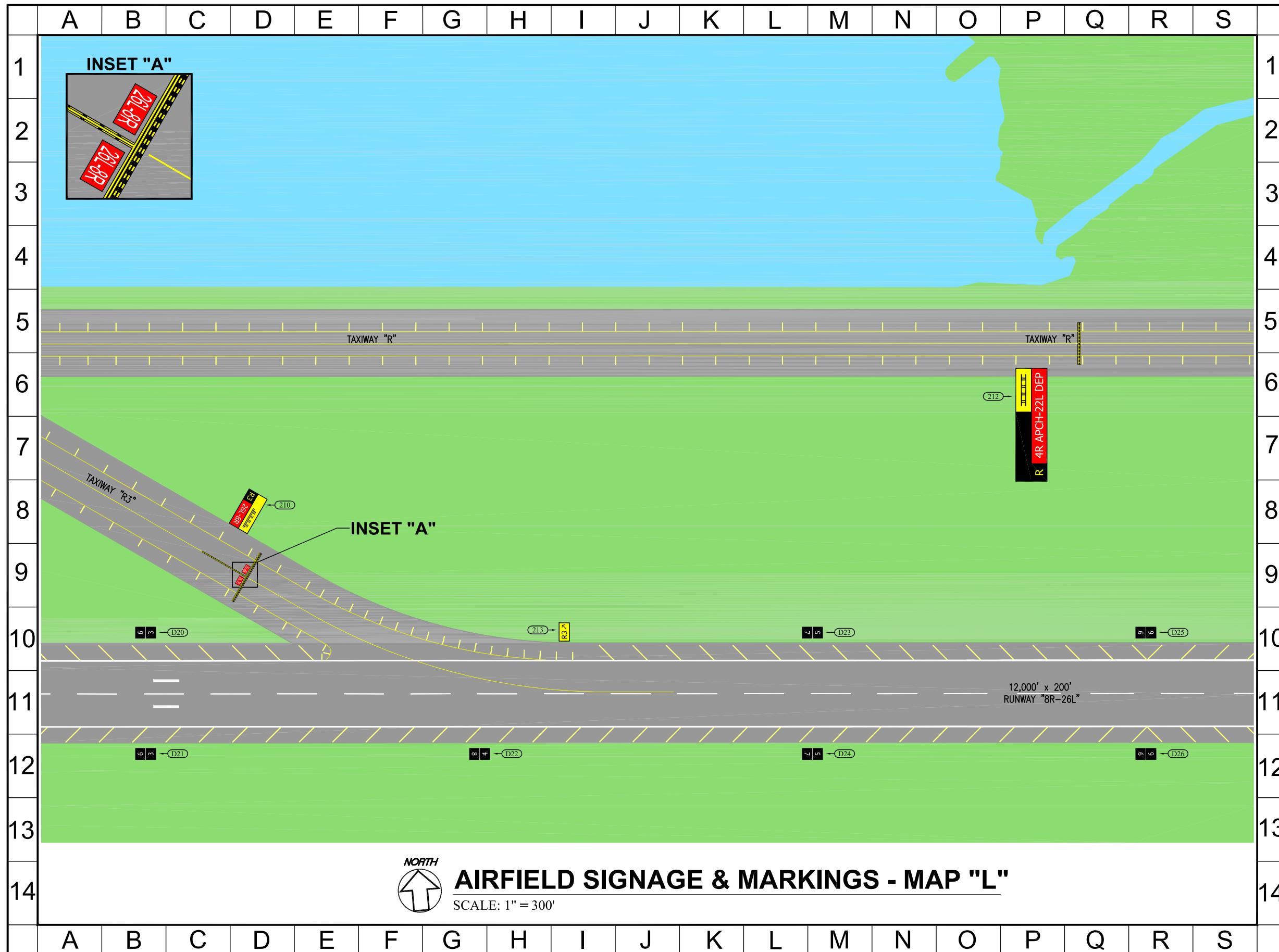

DANIEL K. INOUE INTERNATIONAL AIRPORT  
 AIRFIELD SIGNAGE & MARKINGS EXHIBIT: "MAP L"

Original Date: \_\_\_\_\_ Revision Date: \_\_\_\_\_ FAA Approval: \_\_\_\_\_

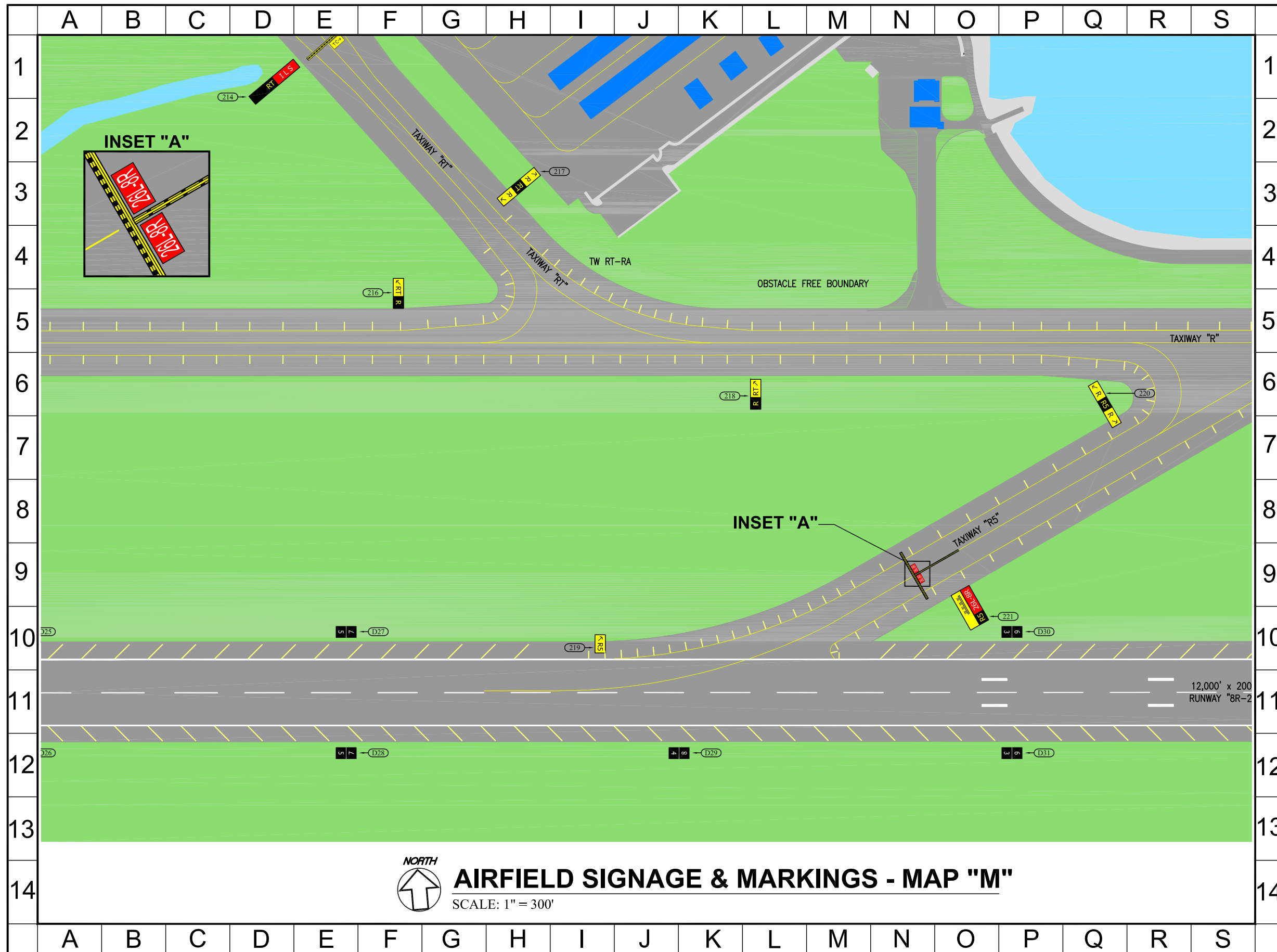

**AIRFIELD SIGNAGE & MARKINGS - MAP "M"**

SCALE: 1" = 300'

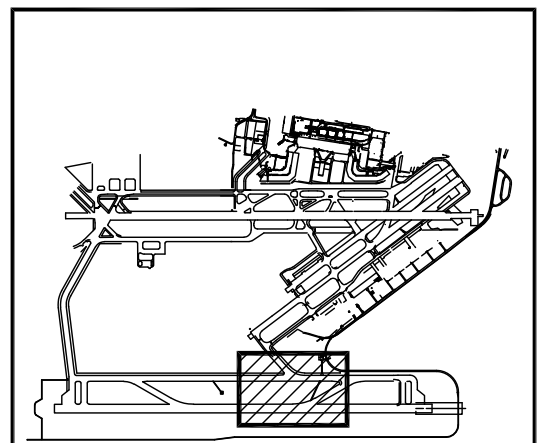

DANIEL K. INOUE INTERNATIONAL AIRPORT

|                             |                     |
|-----------------------------|---------------------|
| AIRFIELD SIGNAGE & MARKINGS | EXHIBIT:<br>"MAP M" |
|-----------------------------|---------------------|

Original Date: \_\_\_\_\_ Revision Date: \_\_\_\_\_ FAA Approval: \_\_\_\_\_

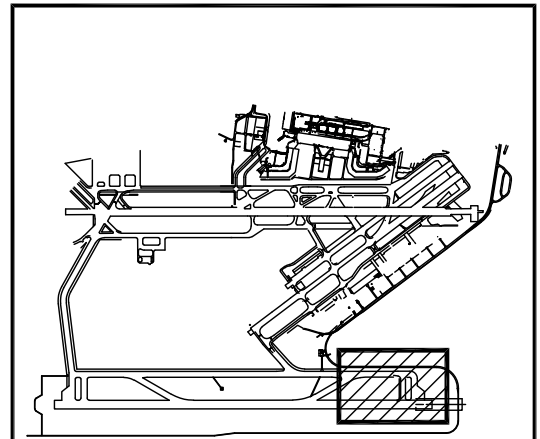
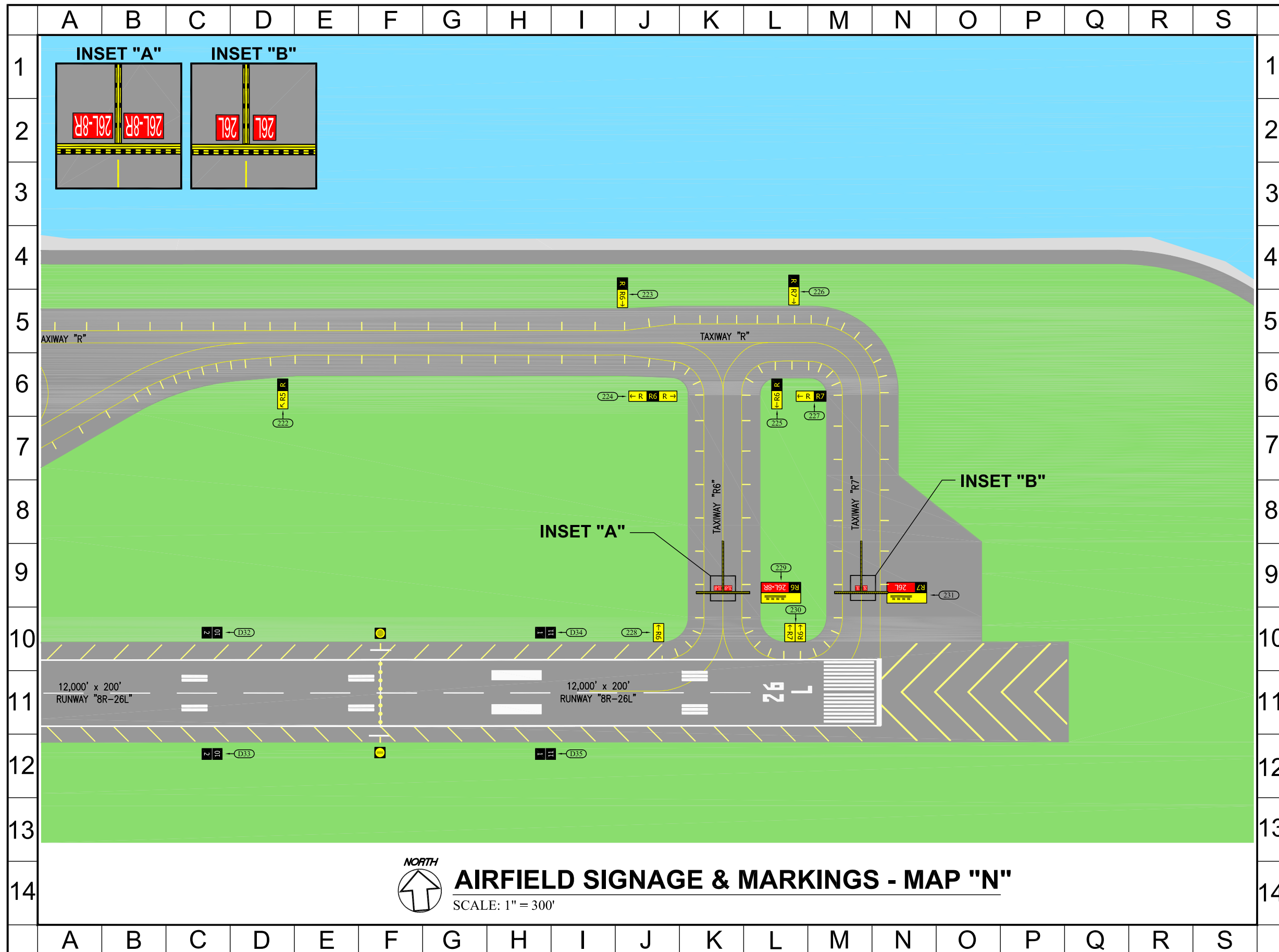

DANIEL K. INOUE INTERNATIONAL AIRPORT  
 AIRFIELD SIGNAGE & MARKINGS EXHIBIT: "MAP N"

Original Date: \_\_\_\_\_ Revision Date: \_\_\_\_\_ FAA Approval: \_\_\_\_\_















KONA INTERNATIONAL AIRPORT AT KEAHOLE  
 AIRFIELD SIGNAGE MAPS AND DATA  
 EXHIBIT MAP "A"  
 Report as of \_\_\_\_\_

| SIGN FRAME |          |     |            |      |              |       | SIGN PANEL |                          |  | Additional Remarks |
|------------|----------|-----|------------|------|--------------|-------|------------|--------------------------|--|--------------------|
| SIGN ID #  | SIGN NO. | MFR | YR INSTALL | SIZE | # OF MODULES | TYPE  | YR REPLACE | LEGEND                   |  |                    |
| A-1        | 1        | ADB | 2007       | 3    | 2            | FLUOR |            | A 35<br>(BLANK)          |  |                    |
| A-2        | 33       | ADB | 2007       | 3    | 2            | FLUOR |            | 35 A<br>=====            |  |                    |
| A-3        | 2        | ADB | 2007       | 3    | 1            | FLUOR |            | ← A<br>(BLANK)           |  |                    |
| A-4        | **       | ADB | 2021       |      |              |       |            | RAMP L →<br>(BLANK)      |  |                    |
| A-5        | 4        | ADB | 2007       | 3    | 2            | FLUOR |            | ← C A<br>(BLANK)         |  |                    |
| A-6        | **       | ADB | 2021       |      |              |       |            | ← A →<br>(BLANK)         |  |                    |
| A-7        | **       | ADB | 2021       |      |              |       |            | ← RAMP L<br>(BLANK)      |  |                    |
| A-8        | **       | ADB | 2021       |      |              |       |            | ← C<br>(BLANK)           |  |                    |
| A-9        | **       | ADB |            |      |              |       |            | C<br>(BLANK)             |  |                    |
| A-10       | **       | ADB | 2021       |      |              |       |            | ← C →<br>A (BLANK)       |  |                    |
| A-11       | **       | ADB | 2021       |      |              |       |            | C →<br>(BLANK)           |  |                    |
| A-12       | 5        | ADB | 2007       | 3    | 3            | FLUOR |            | C ← A →<br>(BLANK)       |  |                    |
| A-13       | 6        | ADB | 2007       | 3    | 2            | FLUOR |            | A C →<br>(BLANK)         |  |                    |
| A-14       | **       | ADB | 2021       |      |              |       |            | RAMP K →<br>(BLANK)      |  |                    |
| A-15       | **       | ADB | 2021       |      |              |       |            | ← RAMP K<br>(BLANK)      |  |                    |
| A-16       | 3        | ADB | 2007       | 3    | 3            | FLUOR |            | C 35-17<br>===== (BLANK) |  |                    |

**KONA INTERNATIONAL AIRPORT AT KEAHOLE**  
**AIRFIELD SIGNAGE MAPS AND DATA**  
**EXHIBIT MAP "A"**  
 Report as of \_\_\_\_\_

| SIGN FRAME |         |     |            |      |              |       | SIGN PANEL |         |  |  | Additional Remarks |  |
|------------|---------|-----|------------|------|--------------|-------|------------|---------|--|--|--------------------|--|
| SIGN ID #  | SIGN NO | MFR | YR INSTALL | SIZE | # OF MODULES | TYPE  | YR REPLACE | LEGEND  |  |  |                    |  |
| A-17       | **      | ADB |            |      |              |       |            | C       |  |  |                    |  |
|            |         |     |            |      |              |       |            | (BLANK) |  |  |                    |  |
| A-18       | D1      | ADB | 2007       | 3    | 1            | FLUOR |            | 10      |  |  |                    |  |
|            |         |     |            |      |              |       |            | 1       |  |  |                    |  |
| A-19       | D2      | ADB | 2007       | 3    | 1            | FLUOR |            | 9       |  |  |                    |  |
|            |         |     |            |      |              |       |            | 2       |  |  |                    |  |

**KONA INTERNATIONAL AIRPORT AT KEAHOLE**  
**AIRFIELD SIGNAGE MAPS AND DATA**  
**EXHIBIT MAP "B"**  
 Report as of \_\_\_\_\_

| SIGN FRAME |          |     |            |      |              |       | SIGN PANEL |   |   |  | Additional Remarks |  |
|------------|----------|-----|------------|------|--------------|-------|------------|---|---|--|--------------------|--|
| SIGN ID #  | SIGN NO. | MFR | YR INSTALL | SIZE | # OF MODULES | TYPE  | YR REPLACE | LEGEND  |   |  |                    |  |
| B-1        | 7        | ADB | 2007       | 3    | 1            | FLUOR |            |    |   |  |                    |  |
|            |          |     |            |      |              |       |            | (BLANK)   |   |  |                    |  |
| B-2        | **       | ADB | 2021       |      |              |       |            |    |   |  |                    |  |
|            |          |     |            |      |              |       |            | (BLANK)   |   |  |                    |  |
| B-3        | **       | ADB |            |      |              |       |            |    |   |  |                    |  |
|            |          |     |            |      |              |       |            | (BLANK)   |   |  |                    |  |
| B-4        | 10       | ADB | 2007       | 3    | 3            | FLUOR |            |    |   |  |                    |  |
|            |          |     |            |      |              |       |            | (BLANK)   |   |  |                    |  |
| B-5        | **       | ADB |            |      |              |       |            |    |   |  |                    |  |
|            |          |     |            |      |              |       |            | (BLANK)   |   |  |                    |  |
| B-6        | **       | ADB | 2021       |      |              |       |            |    |   |  |                    |  |
|            |          |     |            |      |              |       |            |    |   |  |                    |  |
| B-7        | **       | ADB | 2021       |      |              |       |            |    |   |  |                    |  |
|            |          |     |            |      |              |       |            |    |   |  |                    |  |
| B-8        | 13       | ADB | 2007       | 3    | 2            | FLUOR |            |    |   |  |                    |  |
|            |          |     |            |      |              |       |            | (BLANK)   |   |  |                    |  |
| B-9        | 14       | ADB | 2007       | 3    | 1            | FLUOR |            |   |   |  |                    |  |
|            |          |     |            |      |              |       |            | (BLANK)   |   |  |                    |  |
| B-10       | 15       | ADB | 2007       | 3    | 2            | FLUOR |            |  |  |  |                    |  |
|            |          |     |            |      |              |       |            | (BLANK)   |   |  |                    |  |
| B-11       | 17       | ADB | 2007       | 3    | 1            | FLUOR |            |  |   |  |                    |  |
|            |          |     |            |      |              |       |            | (BLANK)   |   |  |                    |  |
| B-12       | D3       | ADB | 2007       | 4    | 1            | FLUOR |            | 8   |   |  |                    |  |
|            |          |     |            |      |              |       |            | 3   |   |  |                    |  |
| B-13       | D4       | ADB | 2007       | 4    | 1            | FLUOR |            | 7   |   |  |                    |  |
|            |          |     |            |      |              |       |            | 4   |   |  |                    |  |

KONA INTERNATIONAL AIRPORT AT KEAHOLE  
 AIRFIELD SIGNAGE MAPS AND DATA  
 EXHIBIT MAP "C"  
 Report as of \_\_\_\_\_

| SIGN FRAME |          |     |            |      |              |       | SIGN PANEL |        |       | Additional Remarks |  |
|------------|----------|-----|------------|------|--------------|-------|------------|--------|-------|--------------------|--|
| SIGN ID #  | SIGN NO. | MFR | YR INSTALL | SIZE | # OF MODULES | TYPE  | YR REPLACE | LEGEND |       |                    |  |
| C-1        | 16       | ADB | 2007       | 3    | 3            | FLUOR |            | H      | 35-17 | (BLANK)            |  |
| C-2        | 18       | ADB | 2007       | 3    | 1            | FLUOR |            | ← H    |       | (BLANK)            |  |
| C-3        | 19       | ADB | 2007       | 3    | 3            | FLUOR |            | H      | ← A → | (BLANK)            |  |
| C-4        | 20       | ADB | 2007       | 3    | 2            | FLUOR |            | A      | H →   | (BLANK)            |  |
| C-5        | 21       | ADB | 2007       | 3    | 1            | FLUOR |            | G →    |       | (BLANK)            |  |
| C-6        | 22       | ADB | 2007       | 3    | 3            | FLUOR |            | G      | 35-17 | (BLANK)            |  |
| C-7        | 23       | ADB | 2007       | 3    | 2            | FLUOR |            | ← G    | A     | (BLANK)            |  |
| C-8        | 24       | ADB | 2007       | 3    | 2            | FLUOR |            | ← A →  |       | (BLANK)            |  |
| C-9        | 25       | ADB | 2007       | 3    | 3            | FLUOR |            | RAMP N | →     | (BLANK)            |  |
| C-10       | 26       | ADB | 2007       | 3    | 2            | FLUOR |            | A      | G →   | (BLANK)            |  |
| C-11       | 27       | ADB | 2007       | 3    | 3            | FLUOR |            | G      | ← A → | (BLANK)            |  |
| C-12       | 28       | ADB | 2007       | 3    | 1            | FLUOR |            | ← G    |       | (BLANK)            |  |
| C-13       | D5       | ADB | 2007       | 4    | 1            | FLUOR |            | 5      |       |                    |  |
|            |          |     |            |      |              |       |            | 6      |       |                    |  |

**KONA INTERNATIONAL AIRPORT AT KEAHOLE**  
**AIRFIELD SIGNAGE MAPS AND DATA**  
**EXHIBIT MAP "D"**  
 Report as of \_\_\_\_\_

| SIGN FRAME |         |     |            |      |              |       | SIGN PANEL |        |  |  | Additional Remarks |  |
|------------|---------|-----|------------|------|--------------|-------|------------|--------|--|--|--------------------|--|
| SIGN ID #  | SIGN NO | MFR | YR INSTALL | SIZE | # OF MODULES | TYPE  | YR REPLACE | LEGEND |  |  |                    |  |
| D-1        | D6      | ADB | 2007       | 4    | 1            | FLUOR |            | 4      |  |  |                    |  |
|            |         |     |            |      |              |       |            | 7      |  |  |                    |  |
| D-2        | D7      | ADB | 2007       | 4    | 1            | FLUOR |            | 3      |  |  |                    |  |
|            |         |     |            |      |              |       |            | 8      |  |  |                    |  |
| D-3        | D8      | ADB | 2007       | 4    | 1            | FLUOR |            | 2      |  |  |                    |  |
|            |         |     |            |      |              |       |            | 9      |  |  |                    |  |

**KONA INTERNATIONAL AIRPORT AT KEAHOLE**  
**AIRFIELD SIGNAGE MAPS AND DATA**  
**EXHIBIT MAP "E"**  
 Report as of \_\_\_\_\_

| SIGN FRAME |          |     |            |      |              |       | SIGN PANEL |         |    |  | Additional Remarks |  |
|------------|----------|-----|------------|------|--------------|-------|------------|---------|----|--|--------------------|--|
| SIGN ID #  | SIGN NO. | MFR | YR INSTALL | SIZE | # OF MODULES | TYPE  | YR REPLACE | LEGEND  |    |  |                    |  |
| E-1        | 29       | ADB | 2007       | 3    | 1            | FLUOR |            | A →     |    |  |                    |  |
|            |          |     |            |      |              |       |            | (BLANK) |    |  |                    |  |
| E-2        | 30       | ADB | 2007       | 3    | 2            | FLUOR |            | A       | 17 |  |                    |  |
|            |          |     |            |      |              |       |            | =====   |    |  |                    |  |
| E-3        | 31       | ADB | 2007       | 3    | 2            | FLUOR |            | 17      | A  |  |                    |  |
|            |          |     |            |      |              |       |            | (BLANK) |    |  |                    |  |
| E-4        | 32       | ADB | 2007       | 3    | 1            | FLUOR |            | ILS     |    |  |                    |  |
|            |          |     |            |      |              |       |            |         |    |  |                    |  |
| E-5        | D9       | ADB | 2007       | 4    | 1            | FLUOR |            | 1       |    |  |                    |  |
|            |          |     |            |      |              |       |            | 10      |    |  |                    |  |

STATE OF HAWAII  
DEPARTMENT OF TRANSPORTATION  
HONOLULU, HAWAII

FORMS

C O N T R A C T

THIS AGREEMENT, made this day \_\_\_\_\_, by and between the STATE OF HAWAII, by its Director of Transportation, hereinafter referred to as "STATE", and «CONTRACTOR», «STATE\_OF\_INCORPORATON», whose business and/or mailing address is «ADDRESS», hereinafter referred to as CONTRACTOR";

WITNESSETH: That for and in consideration of the payments hereinafter mentioned, the CONTRACTOR hereby covenants and agrees with the STATE to complete in place, furnish and pay for all labor and materials necessary for "«PROJECT\_NAME\_AND\_NO»", or such a part thereof as shall be required by the STATE, the total amount of which labor, material and construction shall be computed at the unit and/or lump sum prices set forth in the attached proposal schedule and shall be the sum of «BASIC»-----DOLLARS (\$«BASIC\_NUMERIC») as follows:

TOTAL AMOUNT FOR COMPARISON OF BIDS .....\$«BASIC\_NUMERIC»

which sum shall be provided from STATE funds, all in accordance with the specifications, the special provisions, if any, the notice to bidders, the instructions to bidders, the proposal and plans for «PROJECT NO ONLY» and any supplements thereto, on file in the office of the Director of Transportation. These documents, together with all alterations, amendments, and additions thereto and deductions therefrom, are attached hereto or incorporated herein by reference and made a part of this contract.

The CONTRACTOR hereby covenants and agrees to complete such work from the date indicated in the Notice to Proceed issued by the STATE within «WORKING DAYS», subject, however, to such extensions as may be provided for in writing under the specifications.

For and in consideration of the covenants, undertakings and agreements of the CONTRACTOR herein set forth and upon the full and faithful performance thereof by the CONTRACTOR, the STATE hereby agrees to pay the CONTRACTOR the sum of «BASIC»-----DOLLARS (\$«BASIC NUMERIC») in lawful money, but not more than such part of the same as is actually earned according to the STATE's determination of the actual quantities of work performed and materials furnished by the CONTRACTOR at the unit or lump sum prices set forth in the attached proposal schedule. Such payment, including any extras, shall be made, subject to such additions or deductions hereto or hereafter made in the manner and at the time prescribed in the specifications and this contract. An additional sum of -----«EXTRAS»----- «STATE EXTRAS»DOLLARS (\$«EXTRA NUMERIC») is hereby provided for extra work and shall be provided from State funds.

All words used herein in the singular shall extend to and include the plural. All words used in the plural shall extend to and include the singular. The use of any gender shall extend to and include all genders.

IN WITNESS WHEREOF, the parties hereto have caused this instrument to be duly executed the day and year first above written.

STATE OF HAWAII

\_\_\_\_\_  
Director of Transportation

«CONTRACTOR»

\_\_\_\_\_  
Signature

\_\_\_\_\_  
Print name

\_\_\_\_\_  
Print Title

\_\_\_\_\_  
Date

SAMPLE